

KEITH Mfg. Co.
World Headquarters
800-547-6161
541-475-3802
541-475-2169 fax

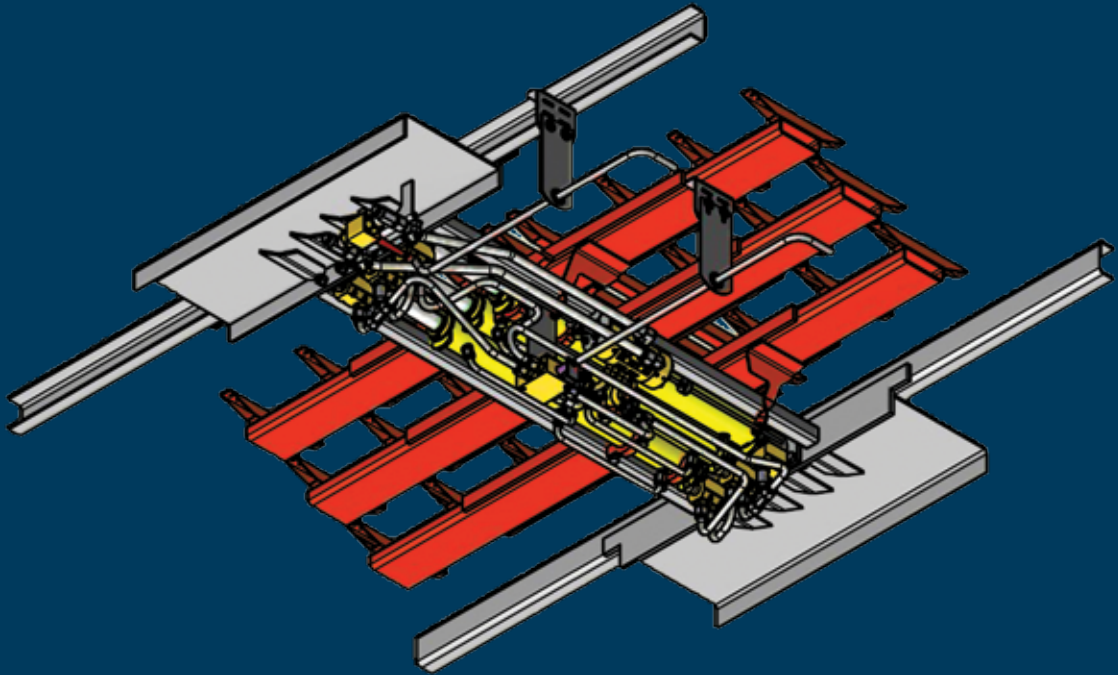

KEITH® RUNNING FLOOR II® DX SAE OWNERS MANUAL Original Instructions

**High Quality Ball Seal
Advanced Switching Valve
Center Frame Design
Cross-Drive Support
Winged Bearings
Snapdown Bearings & Flooring**

**Interchangeable Cylinders
External Check Valves
No Hydraulic Hoses
Strong Drive Frame
Compact Design**



KEITH Mfg. Co.
WORLD HEADQUARTERS
401 N.W. Adler St.
Madras, OR 97741
(800) 547-6161
(541) 475-3802
(541) 475-2169 fax
sales@keithwalkingfloor.com

www.keithwalkingfloor.com

We at KEITH Mfg. Co. are very happy that you have decided to equip your trailer with the KEITH® RUNNING FLOOR II® DX unloading system. We take great pride in the fact that we manufacture the simplest and lowest maintenance self-unloading system available. Installing the KEITH® RUNNING FLOOR II® DX unloader in your trailer provides you with the versatility to load or unload virtually any type of material.

The following pages contain information on the operation of your KEITH® RUNNING FLOOR II® DX unloader.

In addition, we have provided information on the type of hydraulic wet kit that will be needed on your tractor. **Please be sure to use the recommended pumps, filters and pressure relief valves listed, or approved equivalent equipment. It is critical to adhere to the outlined hydraulic wet kit specifications. Failure to follow the guidelines concerning required operation pressures can lead to your system operating improperly.**

Please review the entire manual before operating the KEITH® RUNNING FLOOR II® DX unloading system. If you have any questions or concerns, do not hesitate to contact our factory toll-free at 800-547-6161 or via email at techdept@keithwalkingfloor.com and our trained personnel will be happy to assist you.

Thank you again for equipping your trailer with a KEITH® RUNNING FLOOR II® DX unloader.

Sincerely,

Keith Foster
Founder

Mark Foster
President

WARRANTY AND SAFETY

Warranty.....	2-3
Safety.....	4
Safety Decals.....	5

OPERATION

Safe Start-Up/Shut Down.....	6
Driver Check List.....	7
Operation of Your Running Floor II® DX Unloader.....	8
Component Location Guide.....	9-10
How It Works.....	11-12
Plumbing Diagram.....	13
Start-Up Check List.....	13
Wet Kit Diagram.....	14
Floor Speed.....	14
Wet Kit Information.....	15

TROUBLESHOOTING

Switching Valve Adjustment.....	16-17
Switching Valve Troubleshooting.....	18
Check Valve Troubleshooting.....	19
Replacing a Check Valve.....	20
Control Valve, Ball Valve Troubleshooting.....	21
Hydraulic Cylinders Troubleshooting.....	22
Repairing Cylinders.....	23
KEITH® RUNNING FLOOR II® DX Oil Flow Diagram.....	24
Suggested Preventive Maintenance Schedule.....	25

PARTS

Drive Frame & Related Components.....	26-27
Cross-Drive Assembly.....	28-29
Cylinder Assembly.....	30-31
Hydraulic Tubes & Fittings.....	32-39
Check Valve Assembly.....	40-42
Control Valve Assembly.....	43-44
Switching Valve Assembly.....	45-46
Ball Valve Assembly.....	47
Electric On/Off Ball Valve.....	48-49
Restrictor Valve.....	50
Electric Control Valve.....	51-52
On/Off & Control Valve Handle Assemblies.....	53-55
Front Shield Assembly.....	56
Floor Components.....	57-58

MAINTENANCE AND WARRANTY

Maintenance for New Systems.....	59
Warranty Registration.....	60



KEITH Mfg. Co.
WORLD HEADQUARTERS
401 N.W. Adler St.
Madras, OR 97741
(800) 547-6161
(541) 475-3802
(541) 475-2169 fax
sales@keithwalkingfloor.com

www.keithwalkingfloor.com

RUNNING FLOOR II DX LIMITED WARRANTY (USA/CANADA)

KEITH Mfg. Co. hereby warrants, only to the first owner of a new **KEITH® RUNNING FLOOR II® DX unloader** from the factory or selling distributor that the product shall be free from defects in material and workmanship for a period of one year after delivery to the first registered owner. **Hydraulic parts and components shall be warranted as free from defects in material and workmanship for a period of two years to the first registered owner. This warranty does not cover normal wear and tear and maintenance and is not to be construed as a service contract.**

Owners Obligation: To qualify for warranty coverage, a “warranty card must be completed and returned to Keith Mfg” and the equipment must be subject to normal use and service only.

Definition of Normal Use and Service: Normal use and service means the loading and/or unloading of uniformly distributed, **non-corrosive material, properly restrained and secured, on** properly maintained public roads, with gross vehicle weights not in excess of factory rated capacity. For stationary installations, normal use and service means the conveying of uniformly distributed, non-corrosive materials, with weights not in excess of factory rated capacity.

Sole and Exclusive Remedy: If the product covered hereby fails to conform to the above stated warranty, **KEITH Mfg. Co.’s** sole liability under this warranty and the owner’s sole and exclusive remedy is limited to repair or replacement of the defective part(s) at a facility authorized by **KEITH Mfg. Co.** This is the owner’s sole and exclusive remedy for all contract claims, and all tort claims including those based on the strict liability in tort and negligence. Any defective part(s) must be shipped freight prepaid to **KEITH Mfg. Co.**, Madras, Oregon.

Except As Expressly Set Forth Above, KEITH Mfg. Co. Makes No Warranties:

Express, implied or statutory, specifically: No warranties of fitness for a particular purpose or warranties of merchantability are made. Further, **KEITH Mfg. Co.** will not be liable for incidental damages or consequential damages such as, but not limited to, loss of use of the product, damage to the product, towing expenses, attorney’s fees and the liability you may have in respect to any other reason.

Tort Disclaimer: KEITH Mfg. Co. shall not have any liability in tort with respect to the products, including any liability based on strict liability in tort and negligence.

If This Warranty Violates Law: To the extent any provision of this warranty, contravenes the law of any jurisdiction, that provision shall be inapplicable in such jurisdiction and the remainder of the warranty shall not be affected thereby.



KEITH

A summary of the warranty conditions are as follows:

- The warranty period is for the first equipment owner only
- A warranty period of (1) one year for the entire Running Floor II DX unloader from date of sale by trailer manufacturer.
- A warranty period of (2) two years for the hydraulic parts and components from date of sale by trailer manufacturer.
- The Running Floor II DX unloader must be installed by the trailer builder according to KEITH® installation procedures.
- KEITH recommended maintenance and control procedures must be followed.
- In the case of a malfunction, trailer manufacturer, or KEITH must be informed.

The following components are not covered by the warranty:

- Malfunction of equipment, or caused by equipment, which was not supplied by KEITH Mfg. Co.
- Malfunction caused by the use of dirty oil, or oil of the wrong type.
- Malfunction caused by overheated oil: maximum temperature 60 °C or 140°F.
- Malfunction caused by corrosive materials.
- Malfunction caused by overloading or improper use.
- Malfunction caused by repair work performed by an unauthorized third party.
- Filter elements and components, which are subject to wear-and-tear.
- Defects in electrical components due to incorrect connection and/or incorrect voltage levels.

The warranty is void if:

- The Running Floor II DX unloader is used for purposes which have not been recommended by KEITH Mfg. Co.
- The wet kit does not meet KEITH system recommendations.
- The Running Floor II DX unloader is not installed properly.
- Loads in excess of legal limits are moved with the system without written permission from KEITH Mfg. Co.

To Prevent Possible Injury or Death

1. **Do Not** Operate the floor with the doors closed.
2. **Do Not** Stand behind the trailer or in the discharge area when the floor is operating.
3. **Do Not** Make adjustments to the unloading mechanism with the floor operating.
4. **Do Not** Operate unloader when protective covers and screens are not in place.
5. **Do Not** Go underneath the trailer when floor is operating.
6. **Do Not** Leave the trailer unattended while the unloader is in operation.

Always:

1. Disengage the trailer from the (P.T.O.) hydraulic power unit before service and maintenance.
2. Shut off the power supply before going underneath the trailer.
3. Stay away from any oil leaks when hydraulic pressure is high.
4. Shut off the hydraulic power take off unit (P.T.O.) before moving the trailer.
5. Make certain no one is in the trailer during loading.

!!Keep your hands, body parts and loose clothing away from the floor slats and drive mechanism when the unloading system is in operation!!

Each decal notifies the operator of instructions or potential safety hazards associated with the KEITH® *WALKING FLOOR*® DX unloader. If your dealer has not placed the decals during installation, please follow the decal placement guide provided and place the decals as directed. If you have not been provided with the operational and safety decals, please contact your dealer, or KEITH Mfg. Co. directly and we will provide a set of decals for your application and use. If you have any questions or concerns regarding the decal placement, please don't hesitate to contact your dealer or KEITH Mfg. Co.

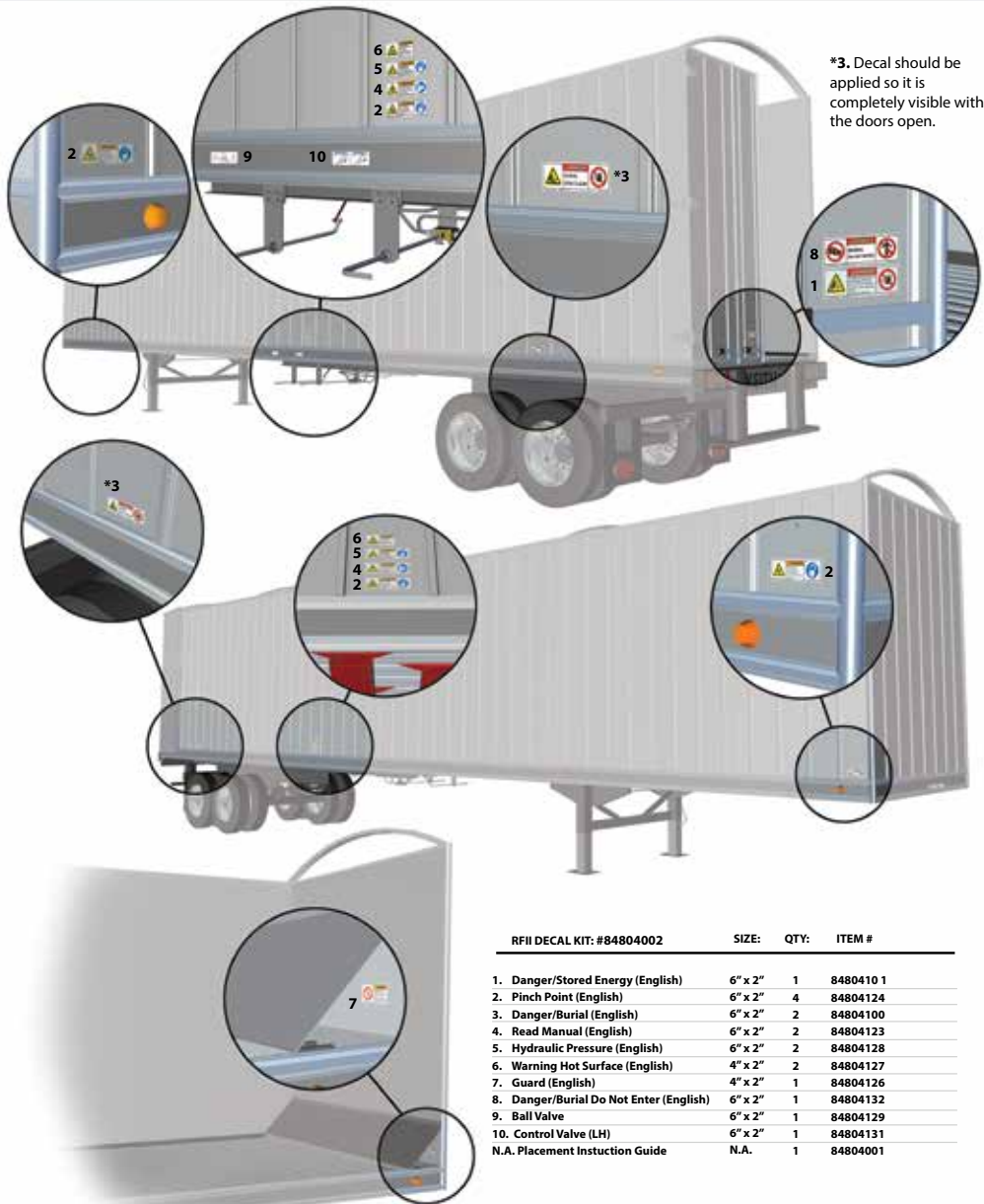
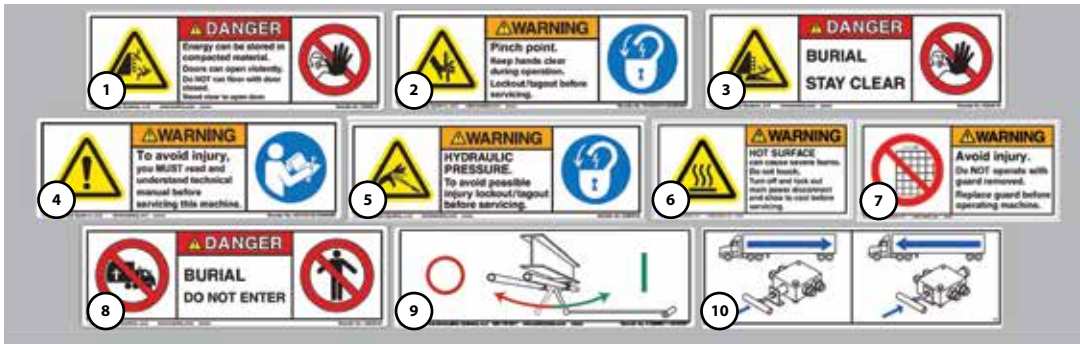

*3. Decal should be applied so it is completely visible with the doors open.

RFII DECAL KIT: #84804002	SIZE:	QTY:	ITEM #
1. Danger/Stored Energy (English)	6" x 2"	1	8480410 1
2. Pinch Point (English)	6" x 2"	4	84804124
3. Danger/Burial (English)	6" x 2"	2	84804100
4. Read Manual (English)	6" x 2"	2	84804123
5. Hydraulic Pressure (English)	6" x 2"	2	84804128
6. Warning Hot Surface (English)	4" x 2"	2	84804127
7. Guard (English)	4" x 2"	1	84804126
8. Danger/Burial Do Not Enter (English)	6" x 2"	1	84804132
9. Ball Valve	6" x 2"	1	84804129
10. Control Valve (LH)	6" x 2"	1	84804131
N.A. Placement Instruction Guide	N.A.	1	84804001

Safe Start-Up/Shutdown

1. Set parking brake on truck and trailer.
2. Open trailer doors fully and secure doors with provided chains or loop rings. **ALWAYS** have doors fully open! **Do not, under any circumstances, engage the Power Take Off / Pump (P.T.O.) or WALKING FLOOR® unloader with the doors of the trailer closed. Do not go under trailer body or enter the trailer while the system is in operation, nor allow anyone to stand or move through the area where the load is being discharged.**
3. Connect hydraulic hoses to power unit (truck).
4. Engage P.T.O. and set to unload RPM.
5. Close the ball valve by pulling the handle outward.
6. While unloading, NEVER leave truck and trailer unattended!
7. After unloading has been completed, stop the floor with all slats in the forward position by placing the ball valve in the open position.
8. Disengage P.T.O.
9. Close doors, disconnect and secure hydraulic hoses.
10. If a problem should arise while unloading, promptly do one of the following:
 - a. Disengage P.T.O. system.
 - b. Open ball valve.

CAUTION

Observations may be made while system is operating for troubleshooting purposes, but NEVER touch any moving part or attempt to make any adjustments to the system with the Power Take Off/Pumping system engaged or the WALKING FLOOR® unloader operating. Do not attempt to make adjustments or repairs without consulting with a trained service technician from your company or contact KEITH Mfg. Co. at 1-800-547-6161 or via email at techdept@keithwalkingfloor.com for further assistance.

Driver Check List

Pre-trip Check: Trailer Empty

1. Inspect hoses and connectors for damage and contamination. Clean all dirt and water from connectors before hooking up.
2. Inspect drive unit for leaking fittings or hoses and visible damage.
3. Open trailer door and inspect flooring for impact damage.
4. Inspect flooring at the rear of the trailer for loose or bent slats that may have popped up.
5. Hook up hydraulic connectors and operate the floor. Inspect for leaks while operating. Engage and disengage ball valve to check for proper operation. Check control valve for proper operation (Forward, reverse).
6. If problems are found, report them to the maintenance shop as soon as possible.
7. Secure trailer door and proceed.

Note: If trailer is loaded, perform steps 3 and 4 after unloading.

As the driver, you will see damage or operational problems before anyone else. Please report it as soon as possible.

Operation of your KEITH® Running Floor II® DX Unloader

UNLOADING

1. Before beginning to unload, make sure the trailer door(s) is/are open.
2. To unload with your KEITH® Running Floor II® DX system, pull the control valve handle all the way out. (See Diagram A.)
3. Make sure that the ball valve, located between the pressure and return lines, is in the closed (run) position. (See Diagram B.) This ball valve is used for the emergency shut-off.
4. Engage the P.T.O., then bring the tractor engine up to the predetermined unloading RPM. Your trailer floor should now be operating.
5. To stop the floor at any time during the loading or unloading process, switch the ball valve to the open (Stop) position. (See Diagram B.)

LOADING

1. To load with your bidirectional KEITH® Running Floor II® DX system, simply push the control valve handle all the way in. (See Diagram A.) Then follow instructions 3, 4 and 5 listed above.

!!Note!!

Make sure the trailer door(s) is/are open BEFORE starting the floor or the trailer door(s) may be damaged. The nose of the trailer may also be damaged by the load force when loading.

Diagram A:
Control Valve

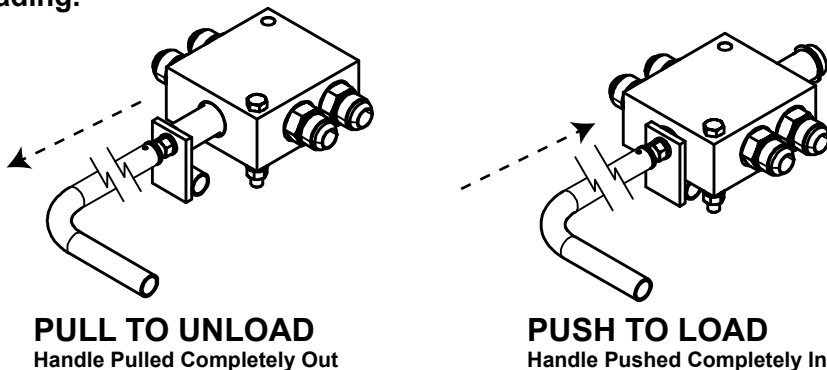
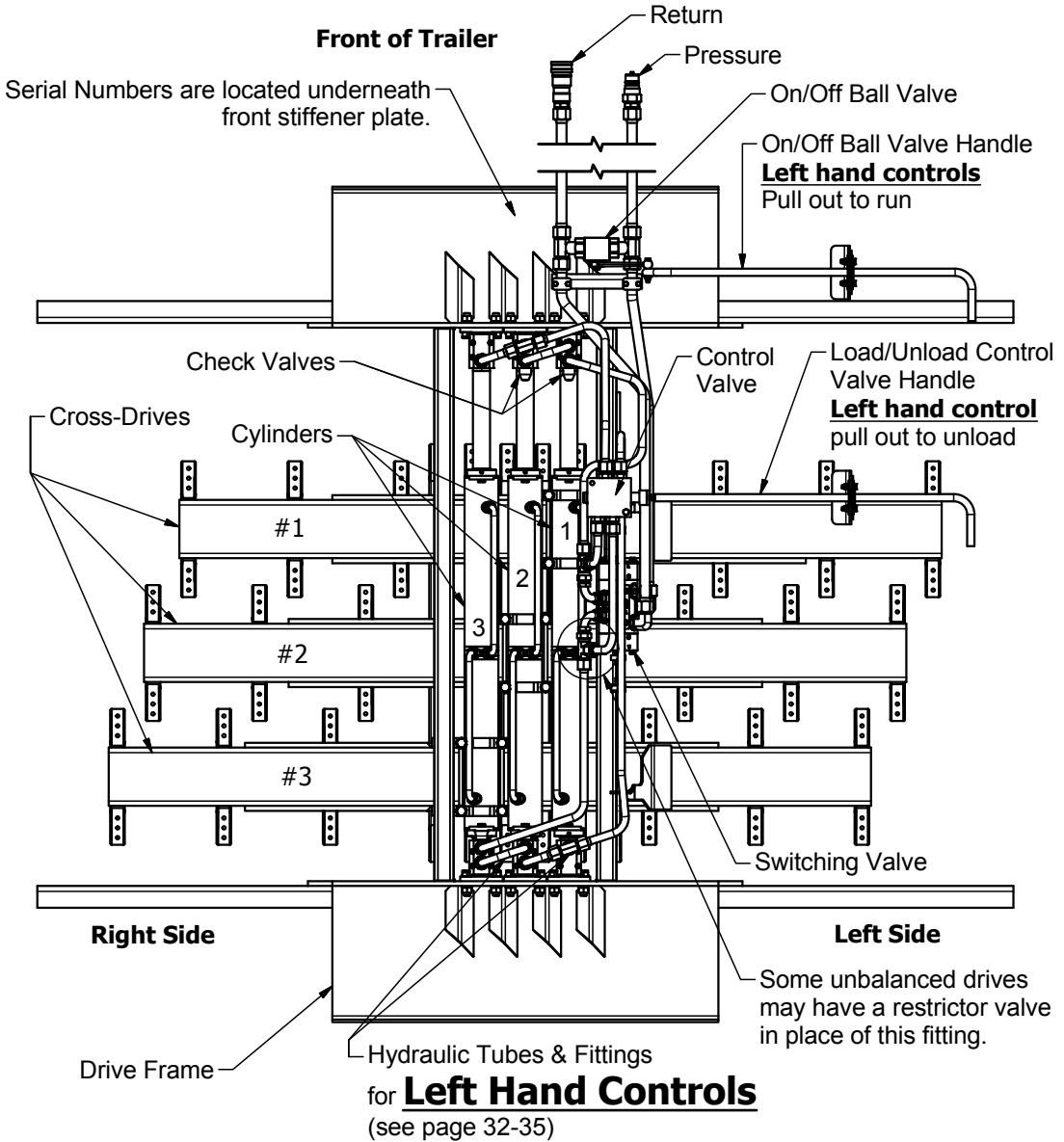

Diagram B:
Ball Valve



Component Location Guide Left Hand Controls



View from underneath trailer

Component Location Guide Right Hand Controls

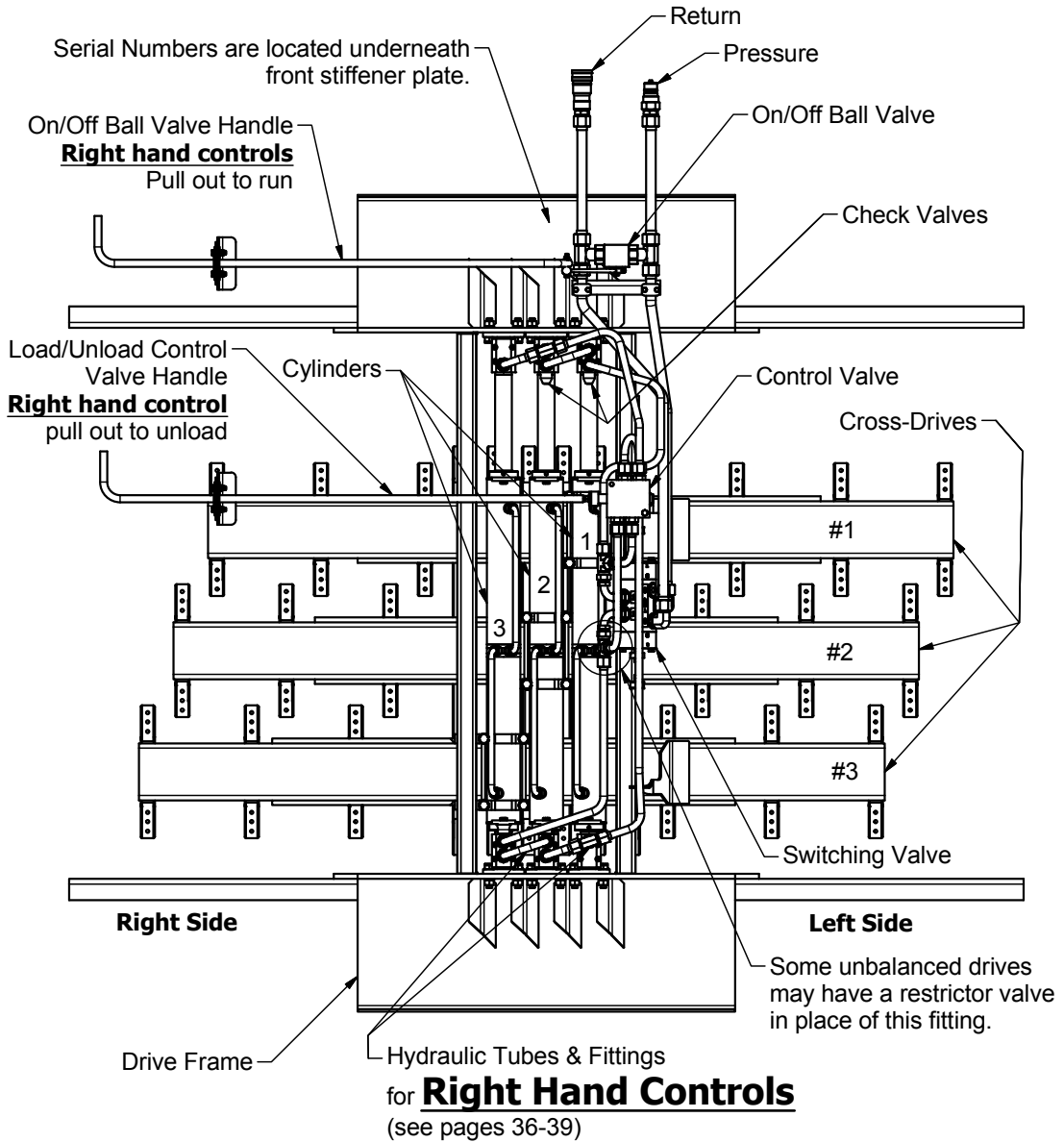

View from underneath trailer

How It Works

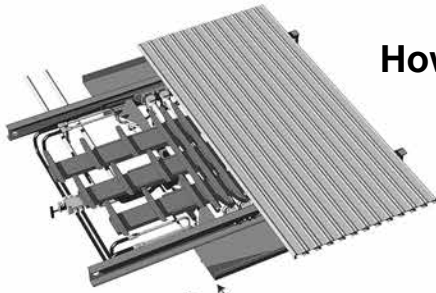

Initial State

All slats/planks at discharge end.

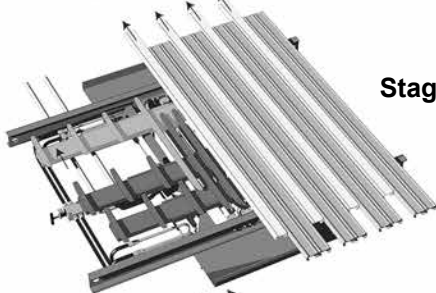

Stage 1

The first group of slats/planks moves under the load.

Load does not move.

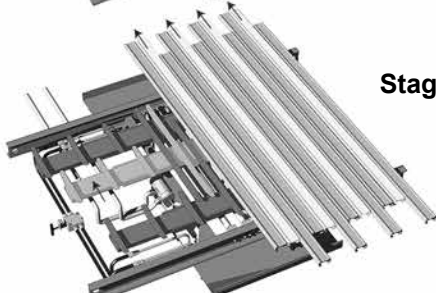

Stage 2

The second group of slats/planks moves under the load.

Load does not move.

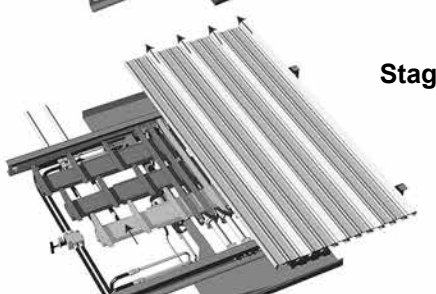

Stage 3

The final group of slats/planks moves under the load.

Load does not move.

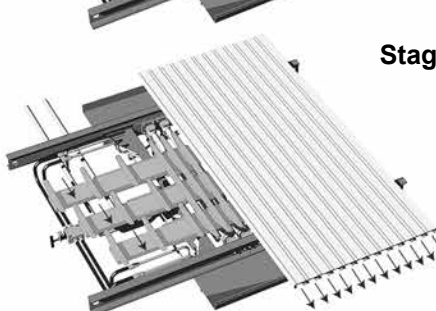

Stage 4

All slats/planks move together.

Load moves toward the discharge end.

(Stages 1, 2 & 3 require more pressure than stage 4.)

Running Floor II® DX Drive How The System Works

Unload Cycle Description-

Phase One:

Cylinder (#1), the left side cylinder, travels toward the front of the trailer. As it reaches the end, the #1 check valve is opened. This releases blocked oil, allowing cylinder (#2), the center cylinder, to travel.

Phase Two:

Cylinder (#2) travels toward the front of the trailer. The #2 check valve is opened, releasing oil and allowing cylinder (#3), the right side cylinder, to travel.

Phase Three:

Cylinder (#3) travels toward the front of the trailer. As it reaches the end of its travel, a loop on the #3 cross-drive pushes the threaded rod connected to the switching valve. The threaded rod is pushed into the switching valve, changing the hydraulic oil flow direction.

Phase Four:

As all three cylinders travel toward the rear of the trailer, the load is transferred to the discharge end. When all cylinders have reached their maximum stroke, the loop on the #1 cross-drive pushes the threaded rod connected to the switching valve. The threaded rod is pushed into the switching valve, changing the flow of oil and starting the cycle over.

Plumbing Diagram

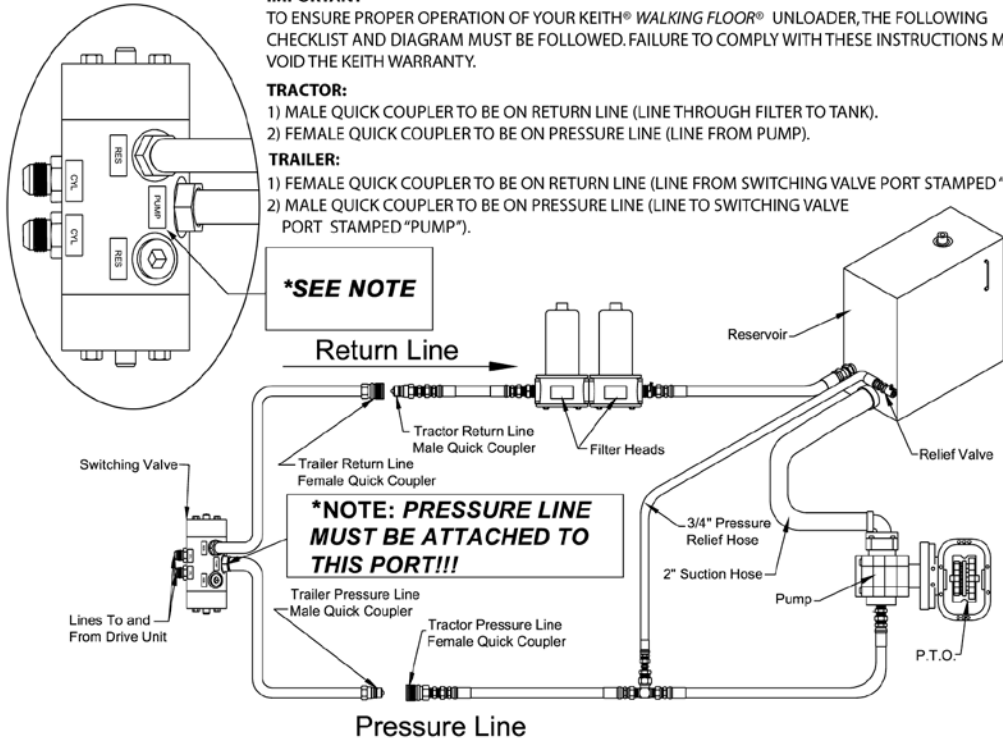

***NOTE: The pressure and return lines must attach to their proper ports on the switching valve. If you have any questions or problems, call KEITH Mfg. Co. at 800-547-6161.**

Start-Up Check List for the KEITH® RUNNING FLOOR II® DX System

Before starting your new KEITH® RUNNING FLOOR II® DX unloader, a quick start-up check should be made.

1. Is your entire system plumbed to the plumbing diagram?
2. *Pump: Will it pump 30-35 GPM at 3000 PSI?
3. *Relief Valve: Is it set at 2800-3000 PSI?
4. Oil: Have you filled the reservoir?
5. Power Take Off: Is the P.T.O. engaged?
6. Quick Disconnects: Are they the same size and type? Are they completely engaged?
7. Ball Valve: Is the ball valve on the drive unit closed?
8. Is the pressure line on the trailer attached to the pressure line on the tractor and the return line on the trailer attached to the return line on the tractor?

*If the information about your pump and relief valve is not known, a pressure/flow check will help determine this information. Be sure that your entire wet kit system meets the requirements of the hydraulic wet kit specifications in this manual.

Wet Kit Diagram

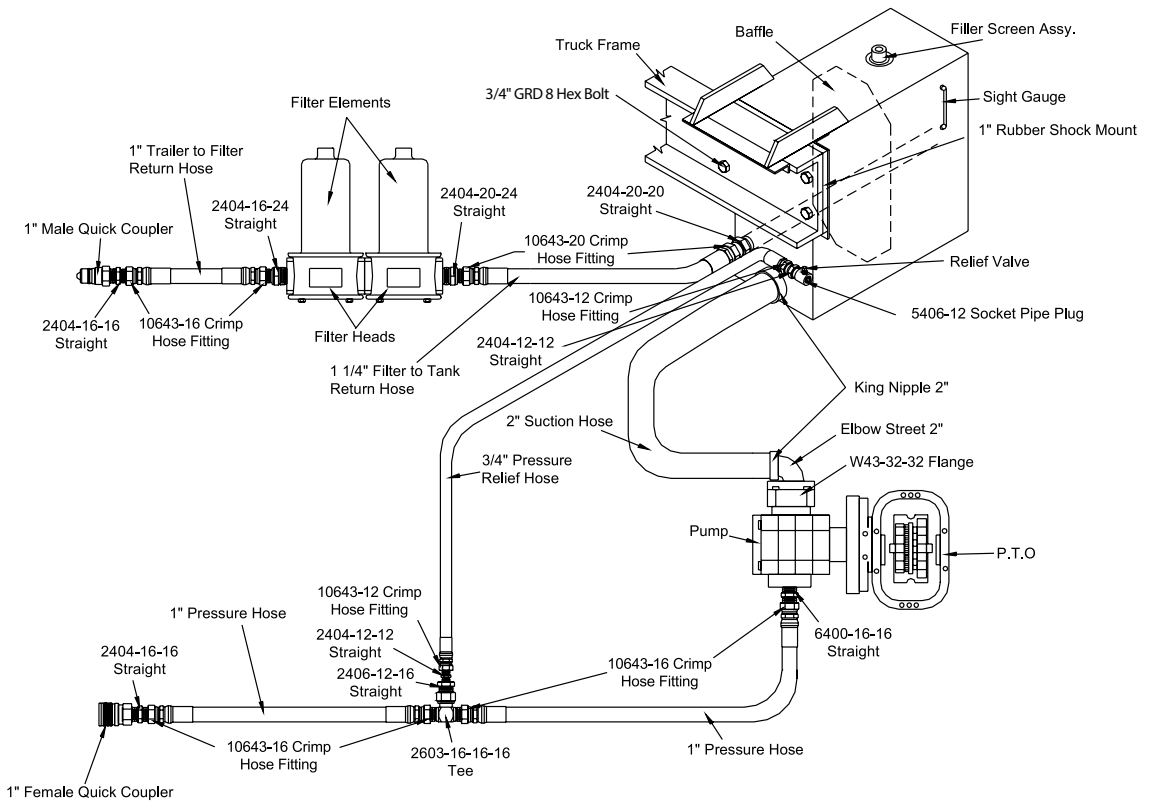

Floor Speed in Relation to Engine RPM

Example: With a P.T.O. output shaft speed rated at 118% of engine RPM, using a P51, P051, P5100 or PL27 type pump with dowelled housing and a 2 1/2" gear. The engine RPM in relation to the floor movement is as follows.

Engine RPM	Pump Output	Speed Ft/ Minute*	Unloading Time 45 ft Trailer
950 RPM	30 g/minute	8.2 ft/minute	7-8 minutes
1430 RPM	45 g/minute	12.5 ft/minute	5-6 minutes
1900 RPM	60 g/minute	16.4 ft/minute	3-4 minutes

Above specifications are for RUNNING FLOOR II® DX drive unit with 3.0" bore cylinders. These are approximate feet per minute only and should be used strictly as a guide.

Note: KEITH Mfg. Co. recommends installing KEITH® RUNNING FLOOR II® DX drive units incorporating 3.5 inch cylinders for use in all semi-trailers with three or more axles.

Wet Kit Information

Transmission:	This wet kit is designed to be used with most transmissions. Power Take Off (P.T.O.) specifications may vary with some transmissions. Please check with your supplier for specific applications.
Oil:	Chevron AW46 hydraulic oil or equivalent. (Lower viscosity in colder climates).
P.T.O.:	Chelsea series 442/489 or Muncie CS6/CS8 Power Take Off unit, rated at approximately 118-125% of engine RPM. (Electronic Overspeed Control is highly recommended).
Pump:	P51, P051, P5100 or PL27 type pump with dowelled housing and a 2 1/2" gear. (Recommend a 2" four bolt, suction port).
Filter:	Filter should be 10 to 25 micron on the return line. Filter should be a double element Zinga or equivalent. Filter head #DF-15-25. MF 2215-25-0-2-0. Filter element #LE-10 or LE-25. (The filter element should be changed after 6 hours initially, and then every 6 months thereafter. This may vary with the operating environment).
Hydraulic Reservoir:	Should hold approximately 1 gallon of oil for every gallon per minute you plan to pump, i.e. 40 GPM = 40 gallon reservoir. Reservoir should hold a minimum of 40 gallons of oil.
Suction Line:	Suction line from the tank to the pump should be no more than 5' in length and a minimum of 2" inside diameter. Example: SAE-100R4. (This type of line has a spiral wire to keep the hose from collapsing under suction).
Pressure Line:	Hose from truck to trailer should be 1" 16 SAE-100R2.
Return Line:	Hose from trailer to filter should be 1" 16 SAE-100R1. Hose from filter to tank should be 1¼" 20 SAE-100R1.
*Pressure Relief Valve:	High quality valve, with the ability to relieve full pump flow at 3000 PSI.

***Note: It is critical that the relief valve is set at no less than 2800 PSI and no more than 3000 PSI.**

Switching Valve Adjustment

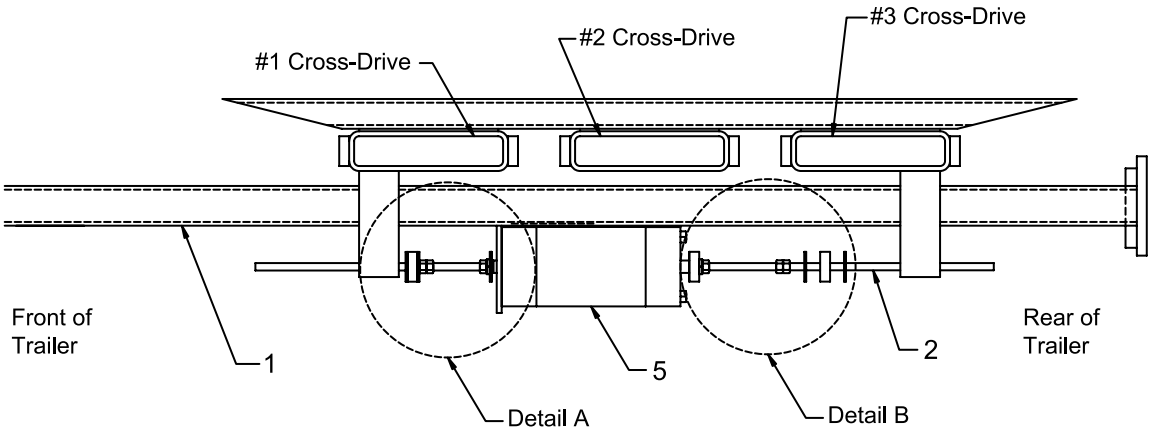

NOTE: This view is from the right side of the trailer. All cylinders are shown to the rear of the trailer.

- | | |
|-----------------------------------|------------------------------|
| 1. 2" x 2" Steel Tube | 5. Switching Valve |
| 2. 3/8" Threaded Rod (typ. 2 pcs) | 6. 3/8" Lock Washer |
| 3. 3/8" Nuts | 7. Switching Valve Grommet |
| 4. 3/8" Flat Washers | 8. Switching Valve Limit Cap |

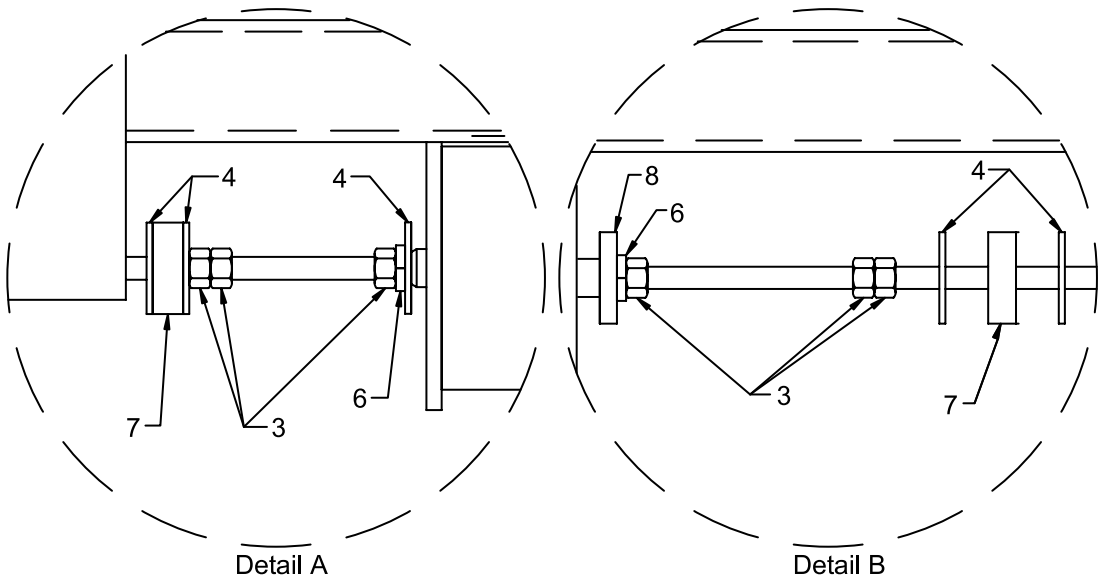

Switching Valve Adjustment

Tools needed: (2) 9/16 inch open-end wrenches.

Most switching valves are incorrectly replaced because they are out of adjustment.

Always adjust the switching valve as described below.

1.	<p>Use the ball valve to stop the drive unit. The ball valve is located toward the front of the drive unit, in front of the hydraulic cylinders. Move the ball valve handle toward the center of the trailer, which will allow the hydraulic oil to by-pass the drive unit.</p>
2.	<p>Loosen the 3/8" jam nuts located on the threaded rods on each end of the switching valve. On each threaded rod there are two flat washers and a grommet. The 3/8" jam nuts are located between the switching valve and the washers. After loosening the nuts, adjust them toward the switching valve. Doing this will throw the switching valve out of adjustment. Repeat the process at the other end of the switching valve.</p>
3.	<p>Start the truck engine and engage the P.T.O. Let the clutch out slowly. Pull the ball valve handle toward the driver's side. The drive unit will move to the load or unload direction. The system will lock up and be under high pressure when the cylinders reach the end of the stroke. Immediately push the ball valve handle toward the center of the trailer. This will allow the hydraulic oil to bypass the system. At this point, the cylinders will be at maximum stroke.</p>
4.	<p>Disengage P.T.O.</p>
5.	<p>Push the threaded rod in the direction that the cylinders are bottomed. Slide the washers and rubber grommet out toward the loop on the cross drive. Turn the 3/8" jam nuts out until they are tight against the washers. Then turn the first nut one extra turn. Bring the second nut up to the first nut and tighten the two together, setting the jam nuts.</p>
6.	<p>Engage P.T.O.</p>
7.	<p>Move the ball valve handle slowly, causing the hydraulic cylinders to travel to the opposite direction. Let the cylinders travel until they lock up. Then push the ball valve handle to the center.</p>
8.	<p>Disengage P.T.O.</p>
9.	<p>Push the threaded rod in the direction that the cylinders are bottomed. Slide the washers and rubber grommet out toward the loop on the other cross drive. Turn the 3/8" jam nuts out until they are tight against the washers. Then turn the first nut one extra turn. Bring the second nut up to the first nut and tighten the two together, setting the jam nuts.</p>
10.	<p>The switching valve adjustment is completed.</p>

Switching Valve Troubleshooting

Problem:	Cylinder (#1) moves toward the front of the trailer. Cylinder (#2) moves toward the front of the trailer. Cylinder (#3) moves toward the front of the trailer; then the system stops.
Cause:	The threaded rod nuts on the discharge end of the switching valve are not adjusted correctly.
Solution:	Break the two nuts apart and adjust toward the rear of the trailer.
Problem:	All three cylinders move toward the rear of the trailer; then the system stops.
Cause:	The threaded rod nuts on the forward end of the switching valve are not adjusted correctly, or there is not enough hydraulic pressure. (See *Note.)
Solution:	Break the two nuts apart and adjust toward the front of the trailer.
Problem:	Floor runs fine empty or with a light load, but will not cycle with a heavy load.
Cause:	The nuts on the threaded rod are slightly out of adjustment, or there is not enough hydraulic pressure. (See *Note.)
Solution:	Break the two nuts apart and adjust them away from the Switching Valve body.
Problem:	After installing a new switching valve, the floor will not move.
Solution:	The switching valve is out of adjustment or the new-style switching valve will not work if the pressure and return lines are backward.
Problem:	The cylinders cycle to the front correctly— cylinder (#1), followed by (#2) then (#3). Then, as all three cylinders begin to move toward the rear, (#3) cross-drive and cylinder move two to three inches back and forth.
Solution:	The switching valve loop on the cross-drive is bent and binding against the threaded rod. Bend the loop away from the threaded rod so that it will enable the threaded rod to travel freely.

***Note:** (If floor stops in the full rear position and the switching valve has switched, you may not have enough oil pressure. Less pressure is required to move the load than to pull the slats 1/3 at a time under the load.)

Check Valve Troubleshooting

The exterior check valve is designed to vent oil from the return side of the cylinder. It does not direct pressurized oil into the cylinder.

Unloading

Problem:	Cylinders (#1) and (#2) extend together toward the front of trailer.
Cause:	The check valve at the forward end of cylinder (#1) has malfunctioned.
Solution:	Rebuild or replace the check valve.
Problem:	Cylinders (#2) and (#3) extend together toward the front of trailer.
Cause:	The check valve at the forward end of cylinder (#2) has malfunctioned.
Solution:	Rebuild or replace the check valve.
Problem:	All three cylinders extend together toward the front of trailer.
Cause:	The check valves at the forward end of cylinders (#1) and (#2) have malfunctioned (Unlikely) or oil is leaking in the control valve and “floating” the check valves.
Solution:	Rebuild or replace the check valves or control valve.

Loading

Problem:	Cylinders (#2) and (#3) extend together toward the rear of trailer.
Cause:	The check valve at the rear end of cylinder (#3) has malfunctioned.
Solution:	Rebuild or replace the check valve.
Problem:	Cylinders (#1) and (#2) extend together toward the rear of trailer.
Cause:	The check valve at the rear end of cylinder (#2) has malfunctioned.
Solution:	Rebuild or replace the check valve.
Problem:	All three cylinders extend together toward the rear of trailer.
Cause:	The check valves at the rear end of cylinders (#2) and (#3) have malfunctioned (Unlikely) or oil is leaking in the control valve and “floating” the check valves.
Solution:	Rebuild or replace the check valves or control valve.

See “Replacing a Check Valve” Page 20

The check valves at the rear of the cylinders (discharge end) do nothing when you are unloading. The check valves at the rear are used for loading only.

Note: When empty, some trailers will cycle in sequence forward 1-2-3, then back 3-2-1, (Instead of all slats moving back together). This is not a malfunction; no repairs are needed. When a load is put on a trailer, the drag will cause the floor to sequence properly.

Replacing a Check Valve

Replacing a KEITH® RUNNING FLOOR II® DX external check valve is a simple procedure. The tools required to do this are:

- (1) 1/4" Allen wrench
- (1) 1-1/4" Open end wrench

DISASSEMBLY

Before removing any bolts, run the cylinder away from the check valve in order to free it. Next remove the four socket head 5/16 x 4 1/2" bolts and tube clamp. Loosen the other end of the tubes and remove the check valve.

ASSEMBLY

First, make sure all of the surfaces are clean and the O-rings are in the proper places. Put the new check valve in place making sure it seats flat on the rod end. Put the 5/16" x 4 1/2" socket head bolts in and tighten the bolts down. Attach the hydraulic tubes to the check valve and tighten. Run the floor and check for leaks.

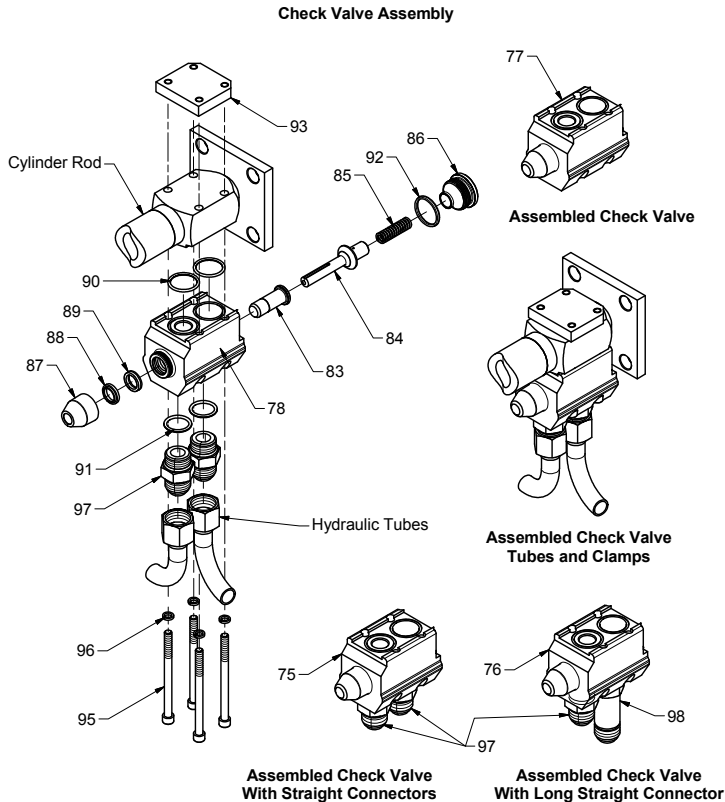

Control Valve, Ball Valve Troubleshooting

Control Valve

The control valve controls the direction of material movement (Load or unload).

Hydraulic oil is directed through the valve by moving the valve handle in or out. When the handle is pulled out, the *WALKING FLOOR*® system unloads. The oil is flowing through the outside hydraulic lines and blocked from flowing through the inside lines. When the valve handle is pushed in, the floor loads. Oil flows through the inside lines and is blocked from flowing through the outside lines.

If the valve spool becomes worn or scored, a hydraulic bypass will be created and the oil will get hot. Isolate the valve by pulling the handle out. Remove the two inside hydraulic lines, cap the valve and plug the lines. If the drive unit runs without the oil getting hot, the valve needs to be changed.

Ball Valve

Note: The ball valve is intended to use as the start and stop valve and the emergency shut off!

The ball valve will start or stop the floor.

The ball valve is open when the handle is pushed in. Oil is allowed to flow through the ball valve and back to the tank. When the handle is pulled out, the valve is closed. Oil flows to the drive unit. If the ball valve gets hot to the touch, the inner seals are worn. This can occur from using the wrong hydraulic pump, bad quick couplers, or from any problem that causes a hydraulic bypass. The ball valve has two Teflon® cup seals; one located on each side of the ball port. If these seals get hot, they will break down. This causes hydraulic oil to slip by, creating heat. You may not be able to move the load because of loss of pressure. The ball valve needs to be rebuilt or replaced.

Hydraulic Cylinders Troubleshooting

Hydraulic Cylinders

Hydraulic cylinders are usually damaged from heat or foreign materials (Causing seals, wear sleeve, etc. to break down).

The way to check the cylinders is to use an infrared heat detector or by touching each end of the cylinder barrel. If you find one end or both that are warmer than the other cylinders, it usually indicates which cylinder is damaged.

Caution: Never touch any component part of the Running Floor II® DX drive or perform this check while the drive unit is operating or P.T.O. engaged. Always shut the system down before performing maintenance.

Problem:	Cylinder (#1) moves fine, (#2) moves fine, (#3) will start to move then suddenly stop. (#3) will then travel four to five inches and move fast.
Solution:	The cylinder (#3) clamp is too tight. This could happen on any one of the three cylinders. Re-torque to 135 ft-lbs.
Problem:	After (#1) cylinder, the left side cylinder, has been changed, the system is operated. (#1) moves to the check valve and opens the check valve. (#2) moves forward, but stops before it reaches the check valve and the hydraulics are at high pressure.
Solution:	Cylinder (#1) was not installed in the correct position. This is not allowing (#2) to travel the distance needed to open the (#2) check valve. The correct measurements for the Running Floor II® 3.0" and 3.5" cylinders are as follows: Cylinder (#1) from end of barrel to front smooth clamp = 1 ½" Cylinder (#3) from end of barrel to front smooth clamp = 1 ½" Cylinder (#2) center cross drive on barrel Do not measure from the cylinder head.
Problem:	In the Unload mode in empty trailer: As all three cylinders travel toward the rear of the trailer, cylinder #3 moves faster than #1 or #2. Cylinder #2 is slowed down because it is bypassing internally or has a mechanical restriction.
Solution:	There is not enough restriction on cylinder (#3). It is recommended to install an RV-2 valve, a restrictor valve, between the switching valve and cylinder or a check valve with a heavier internal spring.

Repairing Cylinders

To repair or replace the cylinder, you have to remove the hydraulic tubes and the check valves on each end of the cylinder that will be removed. There will be a total of twelve 5/8" bolts. Each end of the cylinder will have four and there will be four bolts from the cross-drive. Leave one bolt on each end of the cylinder to hold it in place, but loosen it so that it is almost out. Have one person on each end of the cylinder remove the bolt and let the cylinder down. Use the same method to put the cylinder back in.

Before installing the new cylinder, be sure to check the threaded pad on the cylinder and upper clamp on the cross-drive for damage. If the threads are damaged, replace with a new barrel or cross-drive, if necessary. The threaded pads must mate perfectly and the barrel clamps must be tightened properly to prevent slippage. (135 ft-lbs).

On cylinder (#1) and cylinder (#3), at the end closest to the cross-drive from the end of the barrel to the cross-drive upper clamp.

Note: In all Running Floor II® DX units, cylinder (#1) is located on the left side of the trailer. It is also the first cross-drive that moves to the front of the trailer. We do have different firing on some of our drives. Always check this first, as well as check if all three cylinders are the same.

Rule of Thumb:

If you have a cylinder leaking due to heat, usually all three cylinders will need to be (Or should be) repaired or replaced.

KEITH® Running Floor II® DX Oil Flow Diagram (Unloading Cycle)

Pressure
 Return
 Blocked
 Standing Oil
 Return Oil

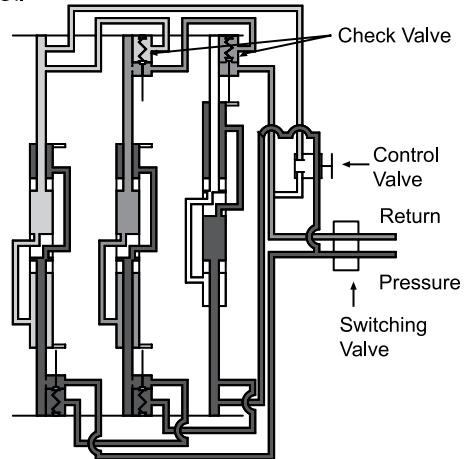
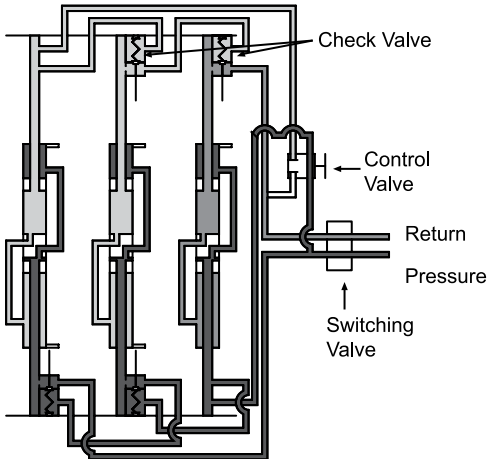

Phase 1

Pressure in the rear of all cylinders as shown in .

Open to return.

Blocked by check valves.

Note: Phase 1 requires more pressure than phase 4.

Phase 2

The #1 cylinder completes its full stroke, opening the check valve and allowing the oil in the #2 cylinder to escape as shown in . (Shows standing oil.) Pressure still in rear of all cylinders as shown in .

Blocked by check valve.

Note: Phase 2 requires more pressure than phase 1.

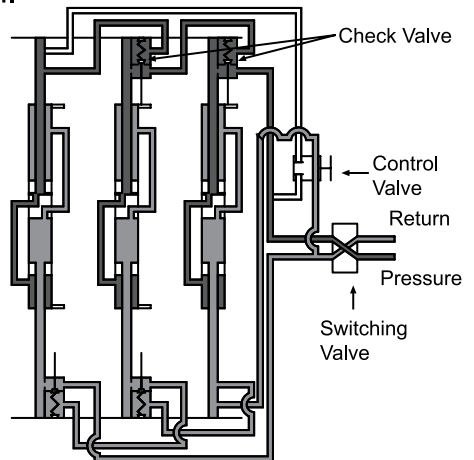
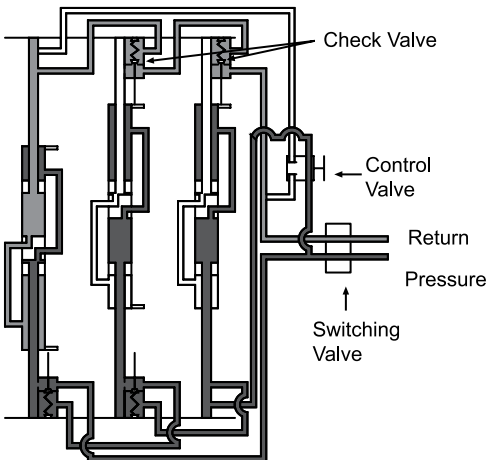

Phase 3

The #2 cylinder completes its full stroke, opening the check valve and allowing the oil in the #3 cylinder to escape to return as shown in . (Shows standing oil.) Pressure still in rear of all cylinders as shown in .

Note: Phase 3 requires more pressure than phase 2.

Phase 4

When the #3 cylinder completes its stroke, the pressure and return are switched by the switching valve, transferring the pressure to the front of all cylinders as shown in . All cylinders are open to return as shown in . All cylinders move to rear of trailer together, moving the load.

Note: Phase 4 requires less pressure than phases 1, 2, or 3.

Suggested Preventive Maintenance Schedule

New Trailer:

1. Check torque on barrel clamp bolts before first load and after the first week of operation. 5/8" bolts/135-lbs.
2. Check torque on floor bolts after one week of operation. 5/16" bolts/22-lbs.
3/8" bolts/42-lbs.
5/8" bolts/180-lbs 9 Slat Kwik Klamp .
5/8" bolts/150-lbs 24 Slat Kwik Klamp.
3/8" bolts/45-lbs Integrated V Slat.
3. Visually check for hydraulic leaks. Check the cylinder area, around the pressure and return hydraulic tubes, around the switching valve, check valves, and the quick disconnect. If leaks are found, retighten the fittings.

Used Trailer:

1. Visually check for hydraulic leaks.
2. Visually inspect the cross-drive support bearing for excessive wear. Replace if needed.
3. Visually inspect the cross-drive tubes and drive shoes for damage. Replace or repair as needed.
4. Inspect flooring for loose slats or bent slats that may have popped up due to impact damage.
5. Visually inspect for excessive wear of the floor bearings over each vehicle tire. Replace as needed.
6. The type of material being transported will affect the timing of the following procedure. A general guide for slat rotation or replacement is after approximately 3,000 loads. Check for wear on the rear of the slats and if they are worn more than 3/4" of the original thickness, it is suggested to remove and rotate the flooring end-for-end for extended life.
7. Pressure wash the drive unit, sub-deck and slats at least twice per year. Once per quarter, if possible.
8. Cycle the system and observe for proper operation in the load and unload modes.
9. Check the torque of the barrel clamp and floor bolts. See torque chart Page 55.

Note: The hydraulic wet kit must meet KEITH Mfg. Co. requirements and must be properly maintained to avoid damaging the *WALKING FLOOR*® system.

Drive Frame & Related Components

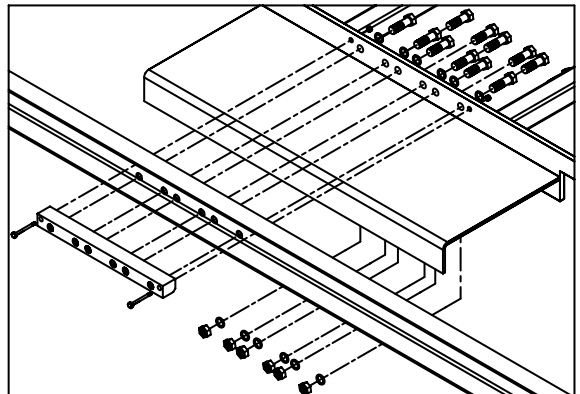
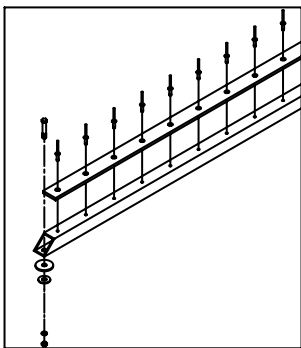
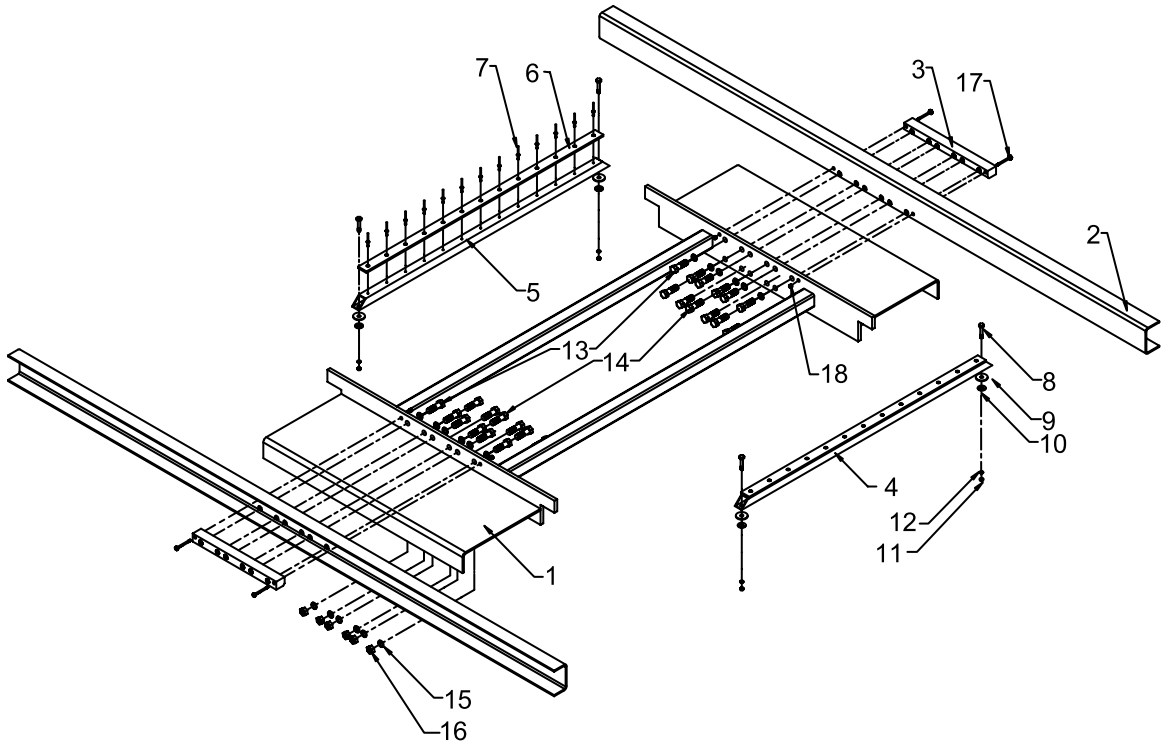

Drive Frame & Related Components

ID #	QUANTITY	DESCRIPTION	PART NUMBER
Drive Frame & Related Components			
-	1	Drive Frame Assembly	-
-	-	Includes items 1-18	-
1 ⁽¹⁾	1	Drive Frame Steel	-
2 ⁽¹⁾⁽²⁾	2	Channel Formed 4"x2 1/4"x3/16"	w/frame
3 ⁽¹⁾	2	Nut Bar Threaded 4.5" Cylinder Centers	04175101
3 ⁽¹⁾	2	Nut Bar Threaded 5.0" Cylinder Centers	01173101
4 ⁽¹⁾	2	Bearing 1/4" Cross-Drive Support Assembly	03467801
-	-	Includes items 5-7	-
5 ⁽¹⁾	1	Bearing Cross-Drive Support Tube	03467701
6 ⁽¹⁾	1	Bearing Cross-Drive Support 1/4" UHMW	03453901
7	13	Rivet 3/16"x1/2"	86528150
8	4	Bolt Hex GR5 3/8"x1 1/4"	86438000
9	4	Washer Large OD 3/8"	86553500
10	4	Washer Flat 3/8"	86554000
11	4	Nut Hex 3/8"	86628500
12	4	Washer Lock 3/8"	86555000
13	12	Bolt Hex GR8 5/8"x2 3/4", (3.0" Cyl)	86466500
13	12	Bolt Hex GR8 5/8"x3", (3.5" Cyl)	86467000
14	12	Bolt Hex GR8 5/8"x2", (3.0" Cyl)	86464500
14	12	Bolt Hex GR8 5/8"x2 1/4", (3.5" Cyl)	86465500
15	24	Washer Lock 5/8"	86559000
16	24	Nut Hex 5/8"	86632000
17	4	Bolt Hex GR5 1/4"x2 1/4", (3.0" Cyl)	86419500
17	4	Bolt Hex GR5 1/4"x2 1/2", (3.5" Cyl)	86420000
18	4	Nut Hex Nylock 1/4"	86626000

(1) Part numbers and descriptions vary based on the drive configuration and application.

(2) Formed Channels are included with frame. In many applications they are non-removable.

Cross-Drive Assembly

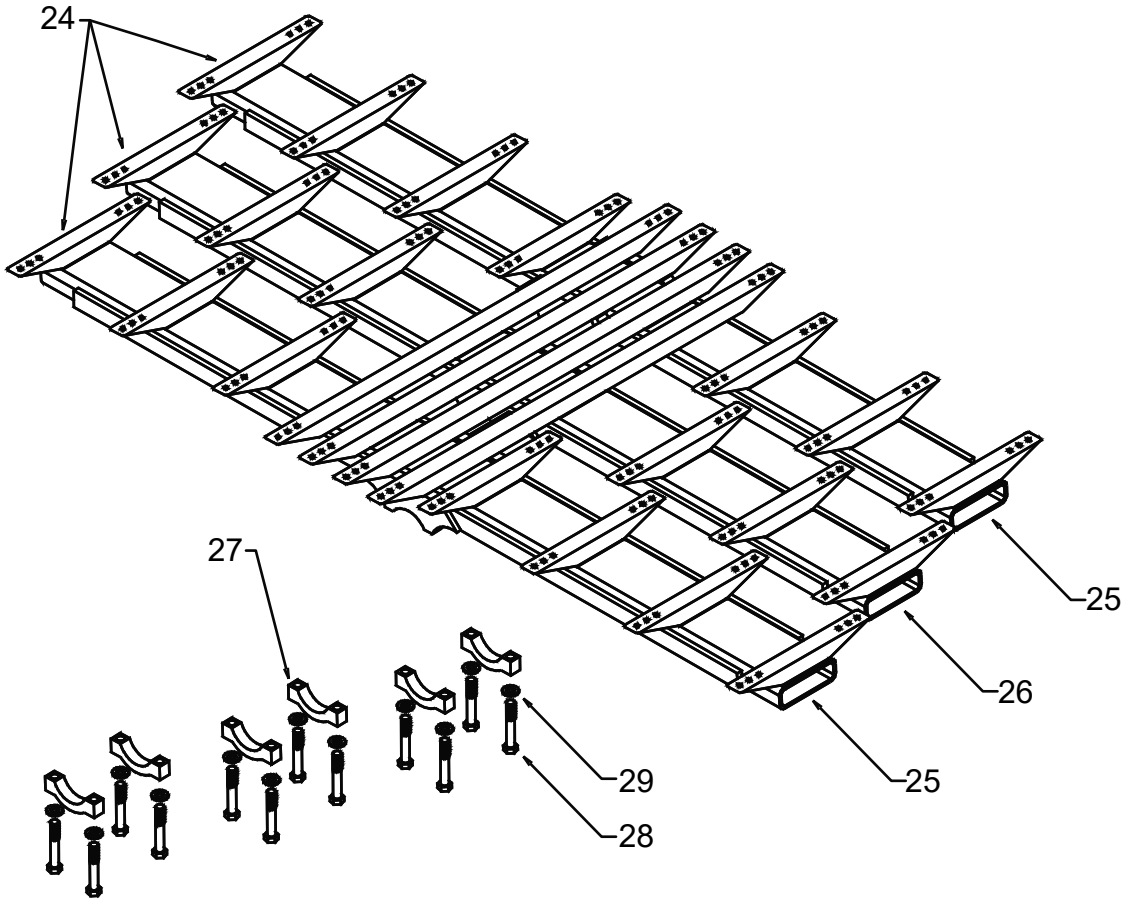

Cross-Drive Assembly

Parts List

ID #	QUANTITY	DESCRIPTION	PART NUMBER
Cross-Drive Assembly			
24 ⁽¹⁾	1	Cross-Drive 24 Slat 3.0" 4.5" Cylinder Center Set	02535501
24 ⁽¹⁾	1	Cross-Drive 24 Slat 3.5" 5.0" Cylinder Center Set	02520501
-	-	Includes items 25 & 26	-
25 ⁽¹⁾	2	Cross-Drive 24 Slat 3.0" 4.5" Cylinder Center #1 & #3	02535502
25 ⁽¹⁾	2	Cross-Drive 24 Slat 3.5" 5.0" Cylinder Center #1 & #3	02520502
26 ⁽¹⁾	1	Cross-Drive 24 Slat 3.0" 4.5" Cylinder Center #2	02535503
26 ⁽¹⁾	1	Cross-Drive 24 Slat 3.5" 5.0" Cylinder Center #2	02520503
27	6	Clamp 3.0" Lower Cross-Drive	03910501
27	6	Clamp 3.5" Lower Cross-Drive	03910601
28	12	Bolt Hex Patchloc GR8 5/8"x4", (3.0" Cyl)	86470010
28	12	Bolt Hex Patchloc GR8 5/8"x4 1/2", (3.5" Cyl)	86470510
29	12	Washer, Nord-Lock 5/8"	86559090

(1) Part numbers and descriptions vary based on drive configuration

Cylinder Assembly

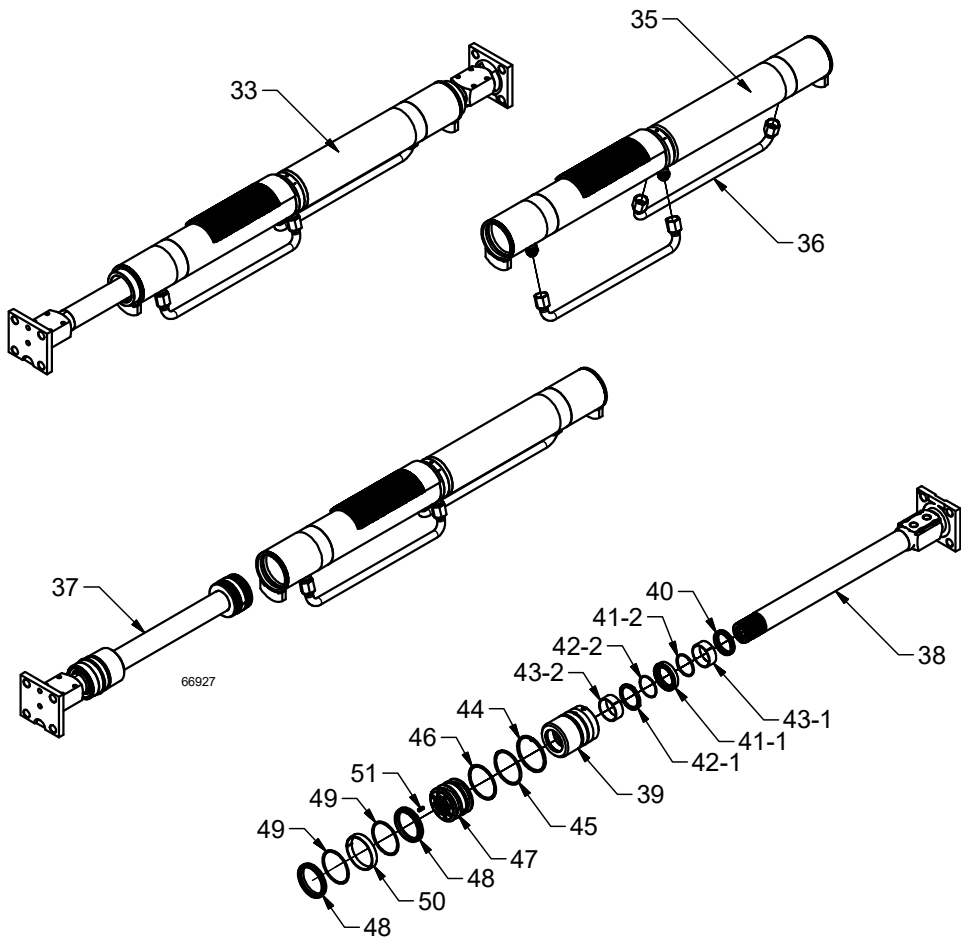

ITEM	QTY	DESCRIPTION	PART NUMBER
33	1	Cylinder 3.0" Standard Assembly	04567901
33	1	Cylinder 3.0" Powder Coated Assembly	04567902
33	1	Cylinder 3.0" Diesel Assembly	04567903
33	1	Cylinder 3.0" Powder Coated w/Triple Lok 2 Fittings Assembly	04567904
33	1	Cylinder 3.0" Remanufactured Assembly	04567999
33	1	Cylinder 3.5" Standard Assembly	04568001
33	1	Cylinder 3.5" Powder Coated Assembly	04568002
33	1	Cylinder 3.5" Remanufactured Assembly	04568099
-	-	Includes items 34-51	-
34	1	Barrel Assembly 3.0" Cylinder	04560901
34	1	Barrel Assembly 3.0" Cylinder -04: w/Triple Lok 2 Fittings	04560902
34	1	Barrel Assembly 3.5" Cylinder	04561001
-	-	Includes items 35 & 36	-

Cylinder Assembly

35	1	Barrel Weld Assembly 3.0" Cylinder	04560601
35	1	Barrel Weld Assembly 3.0" Cylinder -04: w/Triple Lok 2 Fittings	04560604
35	1	Barrel Weld Assembly 3.5" Cylinder	04560701
36	2	Cylinder Cross-Over Tube Assembly	04560801
36	2	Stainless Steel Cross-Over Tube Assembly -04: Powder Coated w/ Triple Lok 2 Fittings	07016701
37	2	Rod w/Piston & Head 3.0" Assembly	02553201
37	2	Rod w/Piston & Head 3.5" Assembly	02553301
-	-	Includes items 38-51	-
38 ⁽¹⁾	1	Rod 45mm w/ Block and Plate	02568501
-	1	Head 3.0" Assembly Cylinder	03808501
-	1	Head 3.5" Assembly Cylinder	03811001
-	-	Includes items 39-46	-
39	1	Head 3.0" Cylinder	06372501
39	1	Head 3.5" Cylinder	06375501
40	1	Wiper Rod 45mm	84426605
41-1	1	Seal Rod Cylinder 45mm	84354200
41-2	1	Seal Backup Rod Cylinder 45mm	w/Seal
42-1	1	Buffer Seal Rod Cylinder 45mm	84400201
42-2	1	Buffer Seal Backup Rod Cylinder 45mm	w/Buffer Seal
43-1	1	Wear Ring Rod Cylinder 45mm	84401105
43-2	1	PTFE Wear Ring Rod Cylinder 45mm (Blue)	84401205
44	1	Lock Wire 3.0" Head Cylinder	03812102
44	1	Lock Wire 3.5" Head Cylinder	03812104
45	1	O-Ring 232 (3.0" Cylinder)	84384200
45	1	O-Ring 236 (3.5" Cylinder)	84384600
46	1	O-Ring Backup 8-232 (3.0" Cylinder)	84392400
46	1	O-Ring Backup 8-236 (3.5" Cylinder)	84392800
-	1	Piston 3.0" Assembly Cylinder	03808101
-	1	Piston 3.5" Assembly Cylinder	03810901
-	-	Includes items 47-51	-
47	1	Piston 3.0" Cylinder	02564801
47	1	Piston 3.5" Cylinder	02553601
48	2	Seal Piston Cylinder 3.0"	84353600
48	2	Seal Piston Cylinder 3.5"	84353800
49 ⁽²⁾	2	Seal Backup Piston Cylinder 3.0" & 3.5"	w/Seal
50	1	Wear Ring Piston 3.0"	84404600
50	1	Wear Ring Piston 3.5"	84404800
51	1	Pin Drive Lock 3/16" x 1/2"	86650400
- (3)	1	Old Seal Kit 3.0" Cylinder Metric	03877501
- (3)	1	New Seal Kit 3.0" Cylinder Metric	06528901
- (3)	1	Old Seal Kit 3.5" Cylinder Metric	03877601
- (3)	1	New Seal Kit 3.5" Cylinder Metric	06529001
- (3)	-	Includes items 40-46 & 48-51	-

(1) Part numbers and descriptions vary based on drive configuration and application.

(2) Backup included with seal.

(3) The seal kit includes all necessary items required to rebuild the entire cylinder. It does not include items such as the Rod or Piston.

* As of date on serial number.

Hydraulic Tubes & Fittings for Left Hand Controls

(see page 33 - 35)

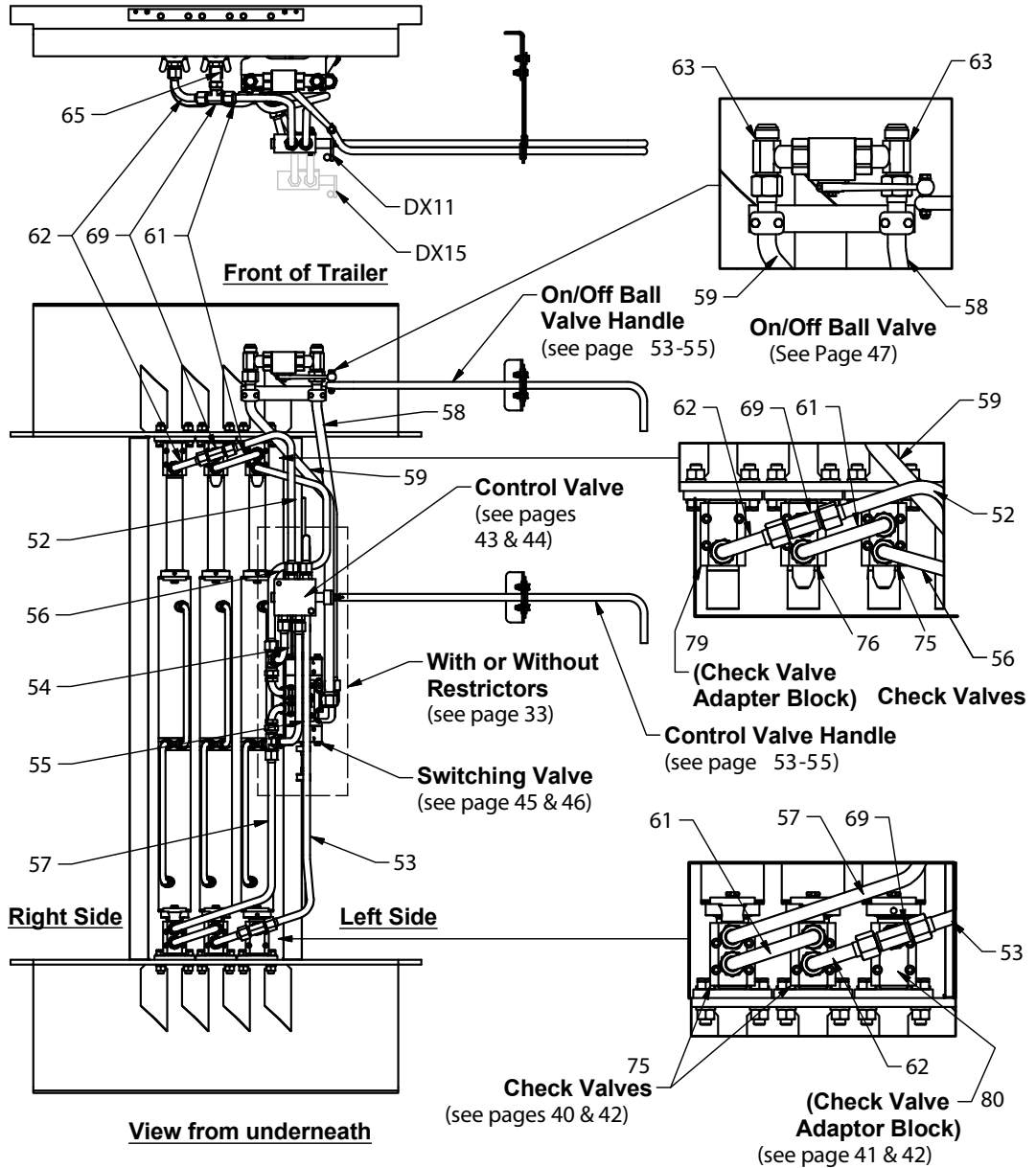

**Hydraulic Tubes & Fittings for
Left Hand Controls**
With or Without Restrictors
(see pages 34 - 35)

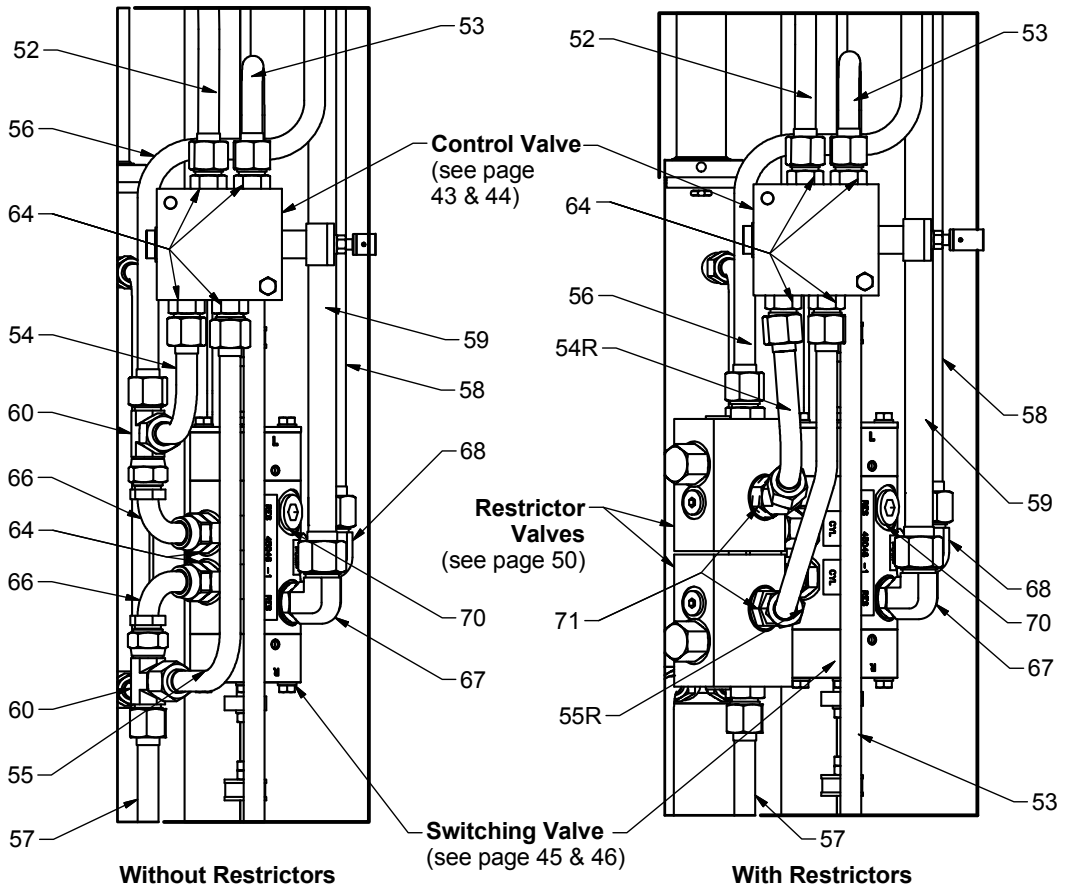

View from underneath

Hydraulic Tubes & Fittings Part List**Left Hand Controls****DX-11, Cylinders on 4.5" Cyl. Centers****DX-15, Cylinders on 4.5" Cyl. Centers****DX-11, Cylinders on 5.0" Cyl. Centers****DX-15, Cylinders on 5.0" Cyl. Centers**

			PART #	PART #	PART #	PART #
KRFII-DX-11 & DX-15, LEFT HAND CONTROLS, 4.5" CYL. CENTERS & 5.0" CYL. CENT						
ID#	QUANTITY	DESCRIPTION	DX-11, 4.5	DX-15, 4.5	DX-11, 5.0	DX-15, 5.0
52	1	#52 Tube	6614601	6699301	6628601	6630001
53	1	#53 Tube	6614501	6699401	6628701	6630101
53-6	1	#53-6 Tube Cyl. Stroke 6"	6630601	6649601	6650001	6649201
54	1	#54 Tube	6614701	6699501	6614701	6699501
54R	1	#54R Tube w/Restrictor	6634701	6699701	6634701	6699701
55	1	#55 Tube	6614801	6699601	6614801	6699601
55R	1	#55R Tube w/Restrictor	6634801	6699801	6634801	6699801
56	1	#56 Tube	6649101	6649101	6628901	6628901
57	1	#57 Tube	6614401	6614401	6629001	6629001
57-6	1	#57-6 Tube Cyl. Stroke 6"	6630701	6630701	6650101	6650101
58	1	#58 Tube	6614001	*	*	*
59	1	#59 Tube	6614101	*	*	*
60	2	6602-12 Tee	84690300	*	*	*
61	2	#61 Tube	6509801	6509801	6509802	6509802
62	2	#62 Tube	6509901	6509901	6509902	6509902
63	2	2601-16-16-16 Tee	84677880	*	*	*
64	6	6400-12 Straight	84685000	*	*	*
65	1	6400L-12 Straight	84685010	*	*	*
66	2	63UA-12 Bent Stem 90°	84683100	*	*	*
67	1	6801-16-12 Elbow 90°	84691700	*	*	*
68	1	6801-16 Elbow 90°	84691800	*	*	*
69	2	6600-12 Swivel Tee	84690800	*	*	*
70	1	6408-12 O-Ring Plug	84686900	*	*	*
71R	2	6802-12 Elbow 45°	84691950	*	*	*

* Indicates the same Part Number for all the different Drive Sizes.

R before # in #ID column is for Right Hand Controls

R after # in #ID column is for drives with Restrictors.

-6 in #ID column is for drives with 6" Stroke.

Hydraulic Tubes & Fittings Part List
Left Hand Controls
DX-11, Cylinders on 6.0" Cyl. Centers
DX-15, Cylinders on 6.0" Cyl. Centers

#ID	QUANTITY	DESCRIPTION	PART #	
			DX-11, 6.0	DX-15, 6.0
KRFII-DX-11 & DX-15, LEFT HAND CONTROLS, 4.5" CYL. & 5" CYL.				
52	1	#52 Tube	6636401	6706701
53	1	#53 Tube	6636501	6706801
53-6	1	#53-6 Tube, Cyl. Stroke 6"	6637301	6706501
54	1	#54 Tube	6614701	6699501
54R	1	#54R Tube w/Restrictor	6634701	6699701
55	1	#55 Tube	6614801	6699601
55R	1	#55R Tube w/Restrictor	6634801	6699801
56	1	#56 Tube	6637101	*
57	1	#57 Tube	6637201	*
57-6	1	#57-6 Tube, Cyl. Stroke 6"	6706601	*
58	1	#58 Tube	6614001	*
59	1	# 59 Tube	6614101	*
60	2	6602-12 Tee	84690300	*
61	2	#61 Tube	6509803	*
62	2	#62 Tube	6509903	*
63	2	2601-16 Tee	84677880	*
64	7	6400-12 Straight	84685000	*
65	2	6400L-12 Straight	84685010	*
66	2	63UA-12 Bent Stem 90°	84683100	*
67	1	6801-16-12 Elbow 90°	84691700	*
68	1	6801-16 Elbow 90°	84691800	*
69	2	6600-12 Swivel Tee	84690800	*
70	1	6408-12 O-Ring Poug	84686900	*
71R	1	6802-12 Elbow 45°	84691950	*

* Indicates the same Part Number for all the different Drive Sizes.

R before # in #ID column is for Right Hand Controls

R after # in #ID column is for drives with Restrictors.

-6 in #ID column is for drives with 6" Stroke.

Hydraulic Tubes & Fittings for Right Hand Controls

(see page 37 - 39)

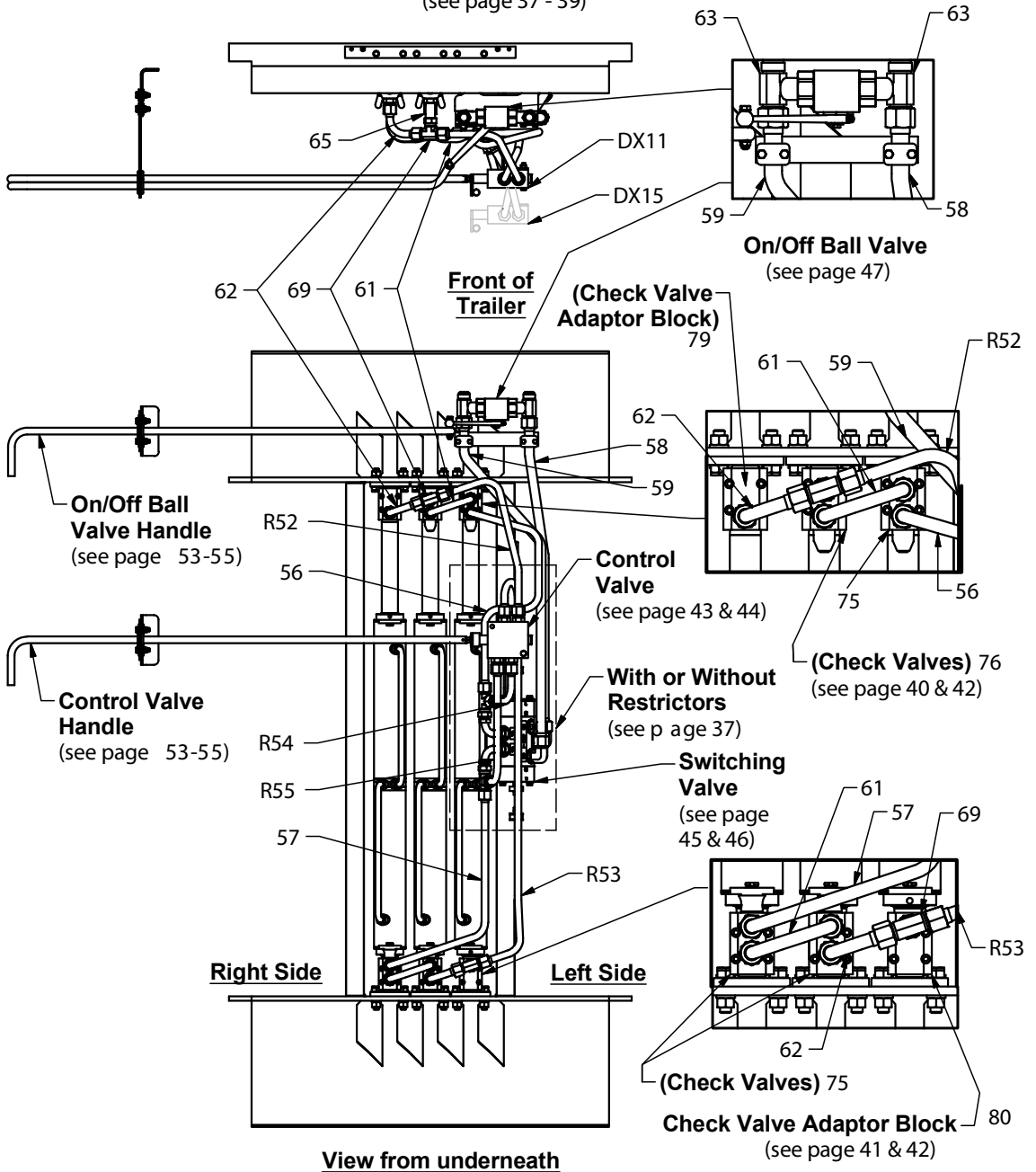

Hydraulic Tubes & Fittings for Right Hand Controls

With or Without Restrictors
(see pages 38 & 39)

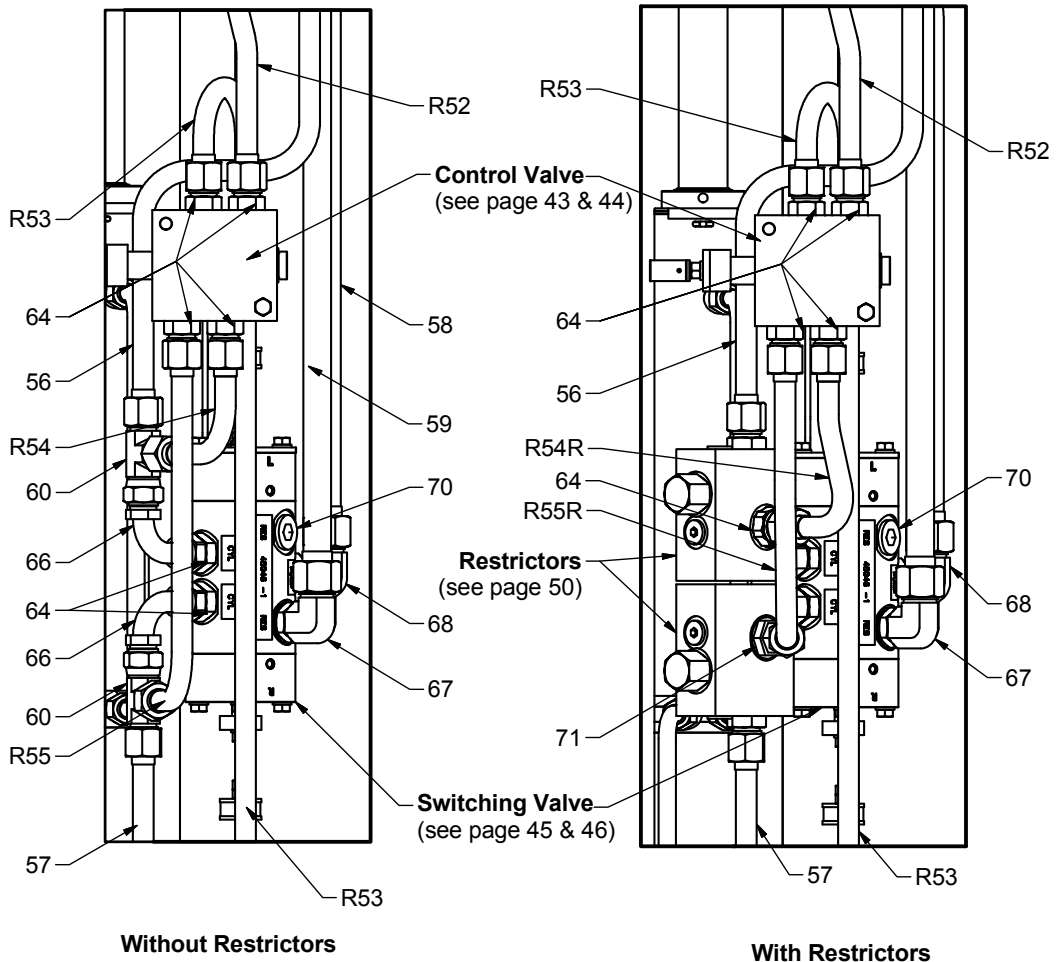

View from underneath

Hydraulic Tubes & Fittings Part List**Right Hand Controls****DX-11, Cylinders on 4.5" Cyl. Centers****DX-15, Cylinders on 4.5" Cyl. Centers****DX-11, Cylinders on 5.0" Cyl. Centers****DX-15, Cylinders on 5.0" Cyl. Centers**

			PART #	PART #	PART #	PART #
KRFII-DX-11 & DX-15, Right Hand Controls, 4.5" Cyl. & 5.0: Cyl.						
#ID	QUANTITY	DESCRIPTION	DX-11, 4.5	DX-15, 4.5	DX-11 5.0	DX-15 5.0
R52	1	#R52 Tube	6640301	6699901	6707401	6708001
R53	1	#R53 Tube	6640401	6700001	6707501	6708101
R53-6	1	#R53-6 Tube Cyl Stroke 6"	6640901	6641001	6708601	6708701
R54	1	#R54 Tube	6640701	6700101	6640701	6700101
R54R	1	#R54R Tube w/Restrictor	6640501	6700301	6640501	6700301
R55	1	#R55 Tube	6640801	6700201	6640801	6700201
R55R	1	#R55R Tube w/Restrictor	6640601	6700401	6640601	6700401
56	1	#56 Tube	6649101	6649101	6628901	6628901
57	1	#57 Tube	6614401	6614401	6629001	6629001
57-8	1	#57-8 Tube Cyl Stroke 8"			6734701	
57-6	1	#57-6 Tube Cyl Stroke 6"	6630701	6630701	6650101	6650101
58	1	#58 Tube	6614001	*	*	*
59	1	#59 Tube	6614101	*	*	*
60	2	6602-12 Tee	84690300	*	*	*
61	2	#61 Tube	6509801	6509801	6509802	6509802
62	2	#62 Tube	6509901	6509901	6509902	6509902
63	2	2601-16 Tee	84677880	*	*	*
64	7	6400-12 Straight	84685000	*	*	*
65	1	6400L-12 Straight	84685010	*	*	*
66	2	63UA-12 Bent Stem 90%%d	84683100	*	*	*
67	1	6801-16-12 Elbow 90%%d	84691700	*	*	*
68	1	6801-16 Elbow 90%%d	84691800	*	*	*
69	2	6600-12 Swivel Tee	84690800	*	*	*
70	1	6408-12 O-Ring Plug	84686900	*	*	*
71R	2	6802-12 Elbow 45°	84691950	*	*	*

* Indicates the same Part Number for all the different Drive Sizes.

R before # in #ID column is for Right Hand Controls

R after # in #ID column is for drives with Restrictors.

-6 in #ID column is for drives with 6" Stroke.

Hydraulic Tubes & Fittings Part List
Right Hand Controls
DX-11, Cylinder on 6.0" Cyl. Centers
DX-15, Cylinder on 6.0" Cyl. Centers

			PART #	PART #
KRFII-DX-11 & DX-15, Right Hand Controls. 6.0" CC				
#ID	QUANTITY	DESCRIPTION	DX-11 6.0	DX-15, 6.0
R52	1	#R52 Tube	6708801	6709501
R53	1	#R53 Tube	6708901	6709601
R53-6	1	#R53-6 Tube Cyl. Stroke 6"	6706001	6709701
R54	1	#R54 Tube	6640701	6700101
R54R	1	#R54R Tube w/Restrictor	6640501	6700301
R55	1	#R55 Tube	6640801	6700201
R55R	1	#R55R Tube	6640601	6700401
56	1	#56 Tube	6637101	*
57	1	#57 Tube	6637201	*
57-6	1	#57-6 Tube Cyl. Stroke 6"	6706601	*
58	1	#58 Tube	6614001	*
59	1	#59 Tube	6614101	*
60	2	6602-12 Tee	84690300	*
61	2	#61 Tube	6509803	*
62	2	#62 Tube	6509903	*
63	2	2601-16 Tee	84677880	*
64	7	6400-12 Straight	84685000	*
65	1	6400L-12 Long Straight	84685010	*
66	2	63UA-12 Bent Stem 90°	84683100	*
67	1	6801-16-12 Elbow 90°	84691700	*
68	1	6801-16 Elbow 90°	84691800	*
69	2	6600-12 Swivel Tee	84690800	*
70	1	6408-12 O-Ring Plug	84686900	*
71R	2	6802-12 Elbow 45°	84691950	*

* Indicates the same Part Number for all the different Drive Sizes.

R before # in #ID column is for Right Hand Controls

R after # in #ID column is for drives with Restrictors.

-6 in #ID column is for drives with 6" Stroke.

Check Valve Assembly

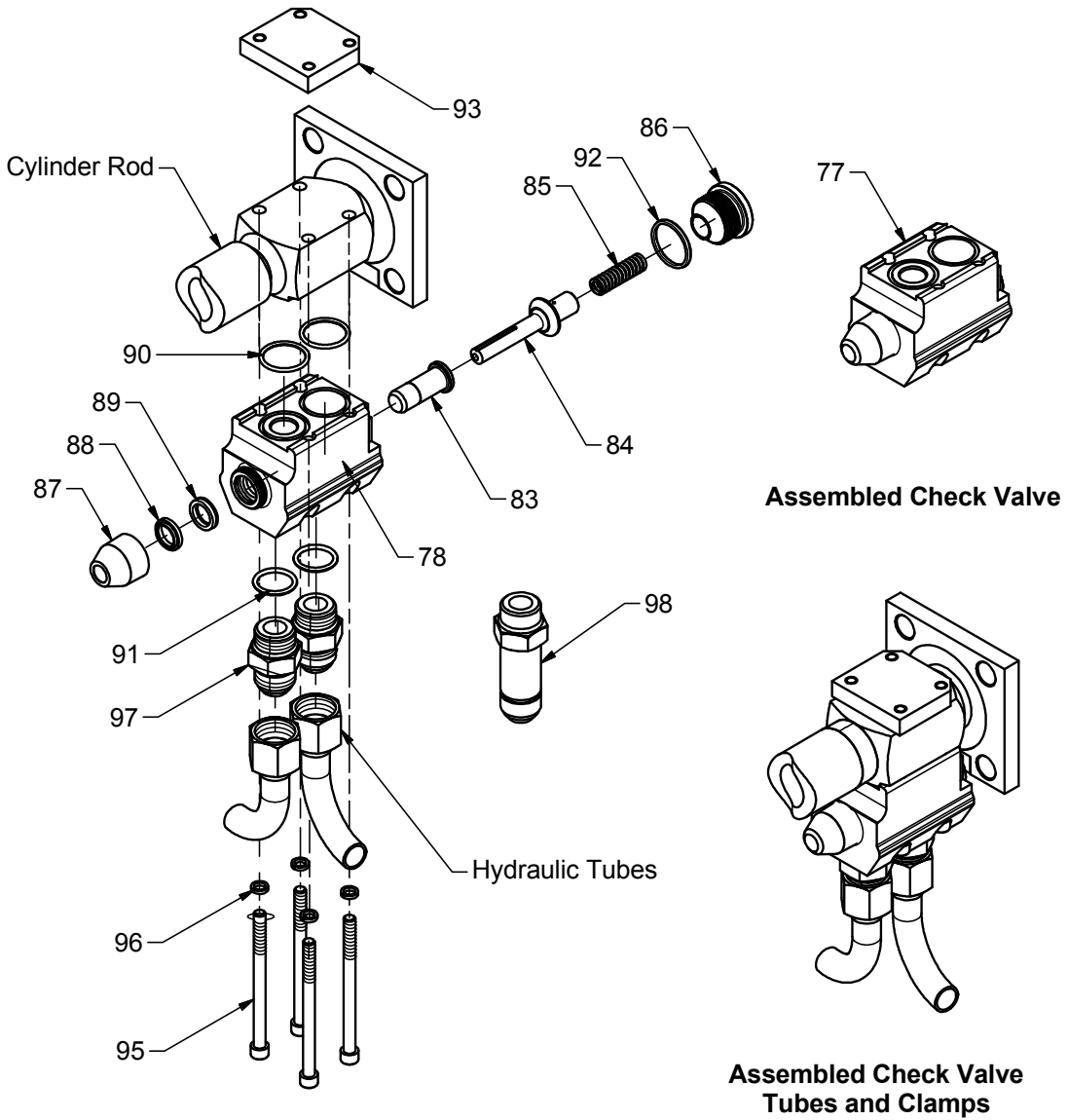

Check Valve Adaptor Block Assembled

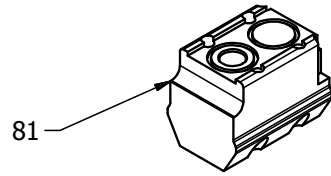
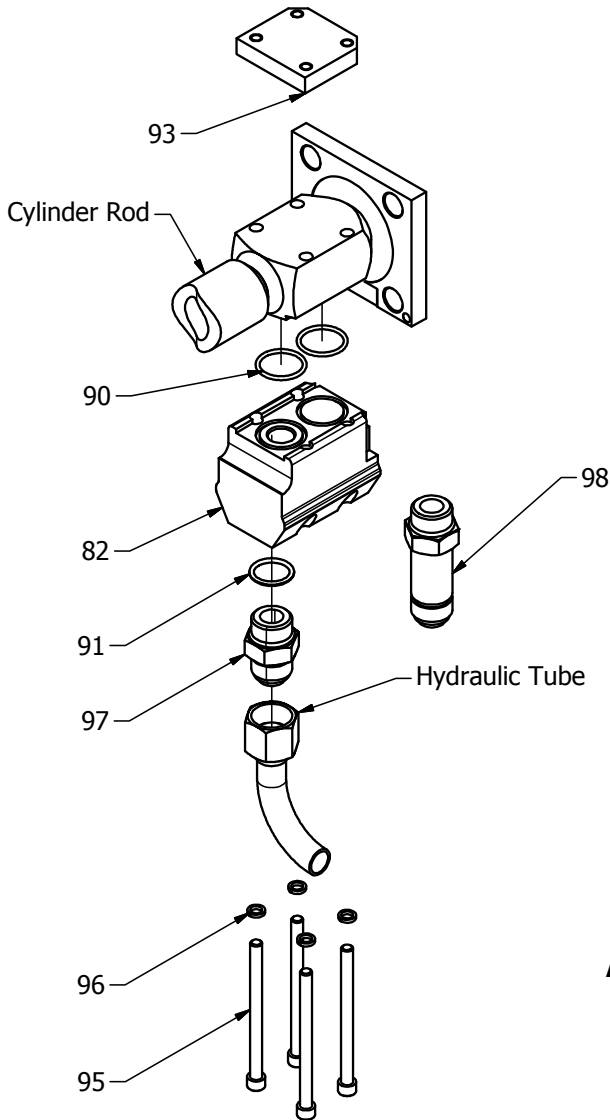

Assembled Check Valve Adaptor Block

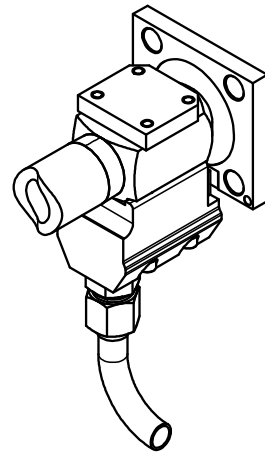

Assembled Check Valve Adaptor Block with Tubes and Clamps

**Check Valve Assembly and
Check Valve Adaptor Block Assembly**

#ID	QUANTITY	DESCRIPTION	PART NUMBER
Check Valve Assembly Parts List			
77	1	Check Valve External Assembly (no connectors)	06520103
-	-	Includes items 78, 83-92	-
78	1	Body Check Valve External	06602901
81	1	Check Valve Adaptor Block Assembly (no connectors)	06613503
-	-	Includes items 82, 86, 90, 91, 92	-
82	1	Body Check Valve Adaptor Block	06613401
83	1	Plunger Check Valve External	01771101
84	1	Rod Check Valve External	01766901
85	1	Spring Check Valve External Large #B-18273	84453400
86	1	Seal Kit Check Valve External	03878101
-	-	Includes Items 87-92	-
87	1	Dust Boot Check Valve External	84801100
88	1	Plunger Wiper Check Valve External	84426800
89	1	Seal Rod 5/8" Check Valve External	84352200
90	2	O-Ring 122	84377800
91	2	O-Ring 912	84387400
92	1	O-Ring 916	84387800
93	1	Clamp Top Check Valve External	02513001
95	4	Bolt Socket 5/16" x 4 1/2"	86432511
96	4	Washer High Collar Lock 5/16"	86553001
97	1 or 2	Staight Threaded Connector W/O-Ring 912	84685000
98	1	Long St. Threaded Connector W/O-Ring 912	84685010

Control Valve Assembly

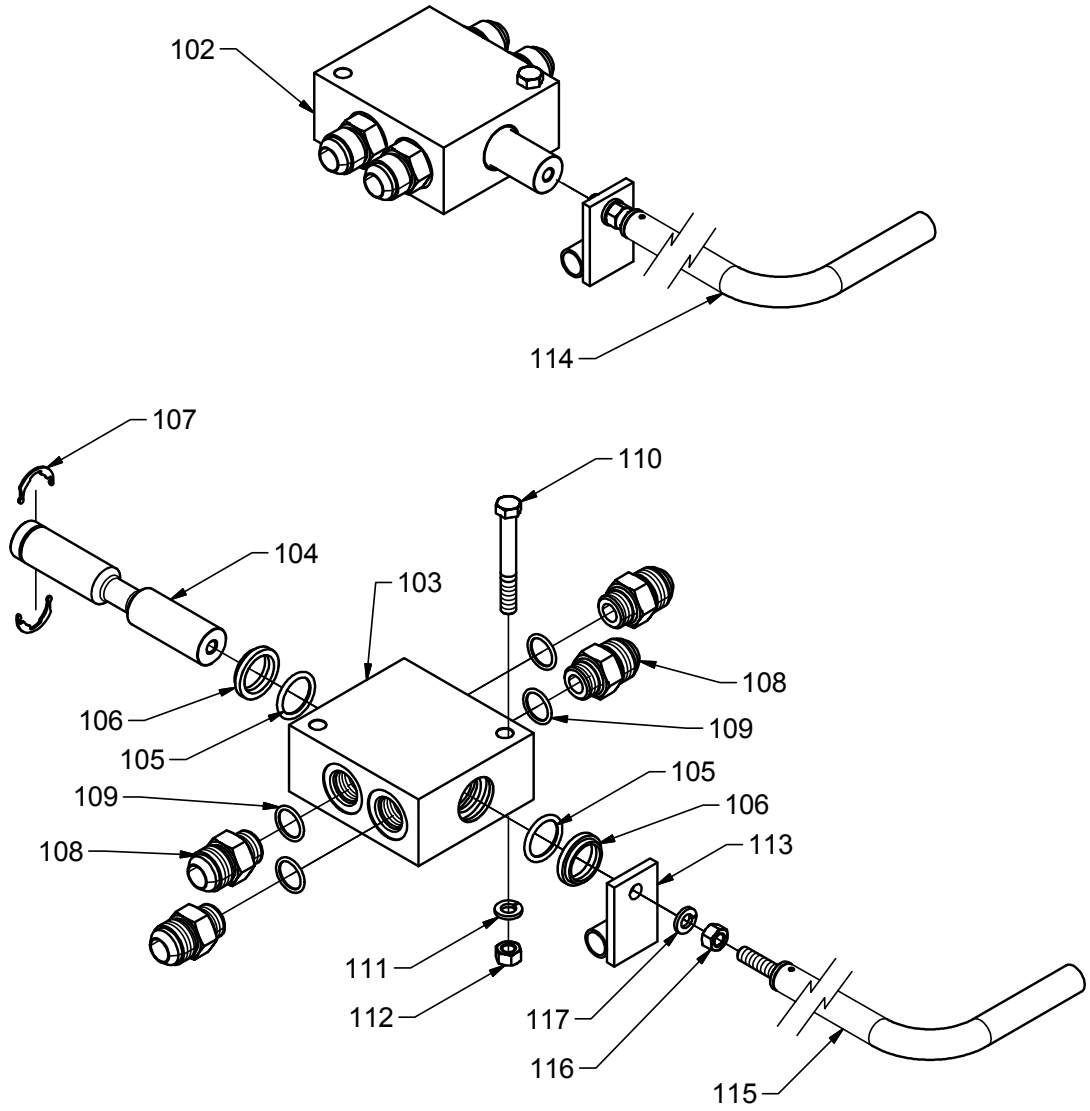

Control Valve Assembly

ID #	QUANTITY	DESCRIPTION	PART NUMBER
Control Valve Assembly			
102	1	Control Valve Load/Unload Assembly	02552701
-	-	Includes items 103-109	-
103	1	Body Control Valve	01049501
104	1	Spool Control Valve	03423201
-	1	Seal Kit Control Valve Load/Unload	03877901
-	-	Includes items 105-107	-
105	2	O-Ring 214 B-70	84381800
106	2	Wiper 1" Rod	84427000
107	1	Snap Ring 2-Piece For Spool	84801000
108	4	6400-12-10 Straight	84684900
109	4	O-Ring 910	84387200
110	2	Bolt Hex GR5 3/8"x3"	86442000
111	2	Washer Lock 3/8"	86555000
112	2	Nut Hex 3/8"	86628500
113	1	Handle Plate	06728001
114	1	Handle Assembly Control Valve Load/Unload	-
		See pages 53, 54 and 55	
		Includes Items 115-117	
115	1	Handle	-
116	1	Nut Hex 3/8"	86628500
117	1	Washer Lock 3/8"	86555000

Switching Valve Assembly

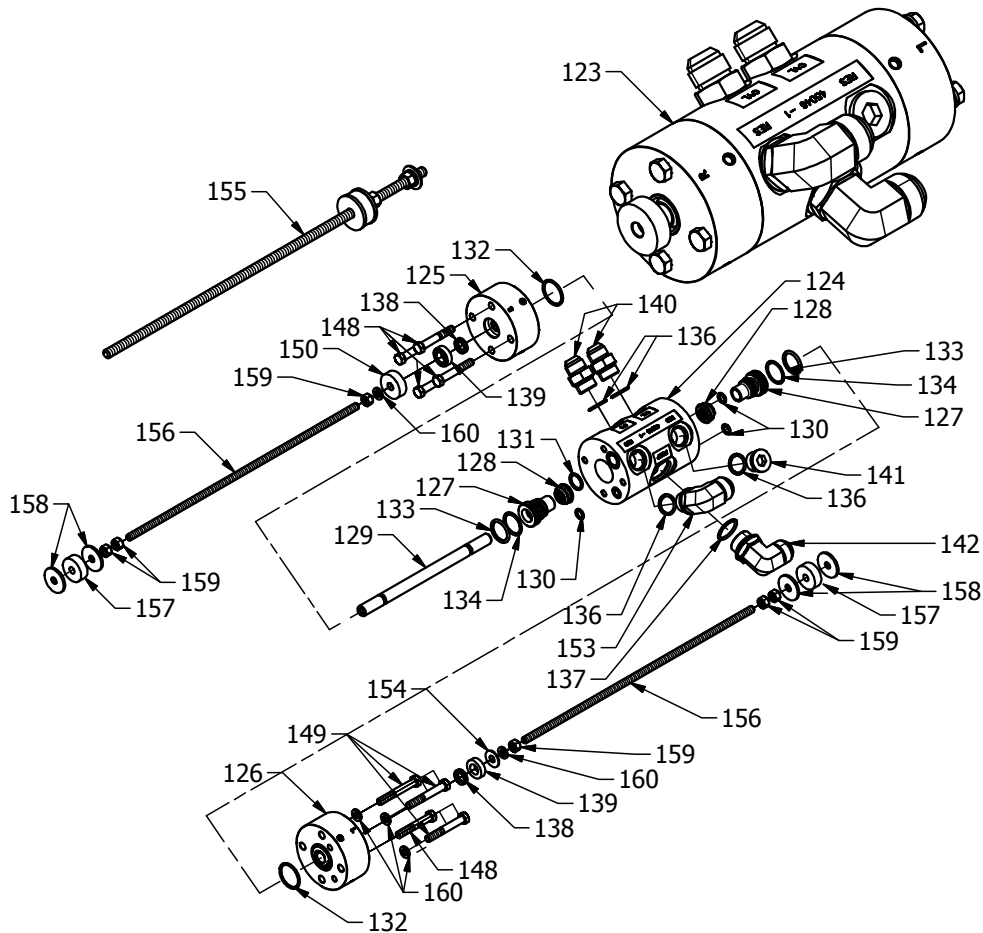

ID #	QUANTITY	DESCRIPTION	PART NUMBER
Switching Valve Assembly			
123 ⁽¹⁾	1	Switching Valve Assembly SAE	03888901
-	-	Includes Items 124-154	-
124 ⁽¹⁾	1	Body Switching Valve	04504601
125 ⁽¹⁾	1	End Cap Right Switching Valve	04504701
126 ⁽¹⁾	1	End Cap Left Switching Valve	04504801
127	2	Poppet Switching Valve	03718901
128	2	Ring Poppet Switching Valve	03718801
129	1	Rod Control Switching Valve	01335501
- ⁽²⁾	1	Seal Kit Switching Valve	03878001
-	-	Includes items 130-139	-
130	3	O-Ring 111	84376200

(1) Part numbers vary for Switching Valves made before 1998.

(2) The Switching Valve Seal Kit contains all necessary components to rebuild all Switching Valve models.

Switching Valve Assembly

131	3	O-Ring 117	84377000
132	2	O-Ring 126	84378200
133	2	O-Ring 216	84382200
134	2	O-Ring Backup 8-216	84391600
135-1	1	O-Ring 906	84386800
135-2	2	O-Ring 908	84387000
136	4	O-Ring 912	84387400
137	1	O-Ring 916	84387800
138	2	Seal Rod 5/8"	84352200
139	2	Wiper Canned 5/8" Rod	84427200
140	2	6400-12-12 Straight	84685000
141	1	6408-12 M O-Ring Socket Plug	84687700
142	1	6801-16-16 Straight Thread Elbow	84691800
144	2	6408-08 M O-Ring Socket Plug	84687500
146	2	Spring S157	84451750
147	2	Filter Element CF0563-46	84012700
148	5	Bolt Hex GR5 3/8"x2 1/2"	86441000
149	3	Bolt Hex GR5 3/8"x3"	86442000
150	1	Cap Limit Switching Valve	02552101
153	1	6801-16-12 Straight Thread Elbow	84691700
154	1	Washer Large OD 3/8"	86553500
155	2	Rod Threaded Assembly Switching Valve	03869701
-	-	Includes Items 156-160	-
156	1	Threaded Rod 3/8"x18"	86603000
157	1	Switching Valve Grommet	83217500
158	2	Washer Large OD 3/8"	86553500
159	3	Nut Hex 3/8"	86628500
160	1	Washer Lock 3/8"	86555000

Ball Valve Assembly

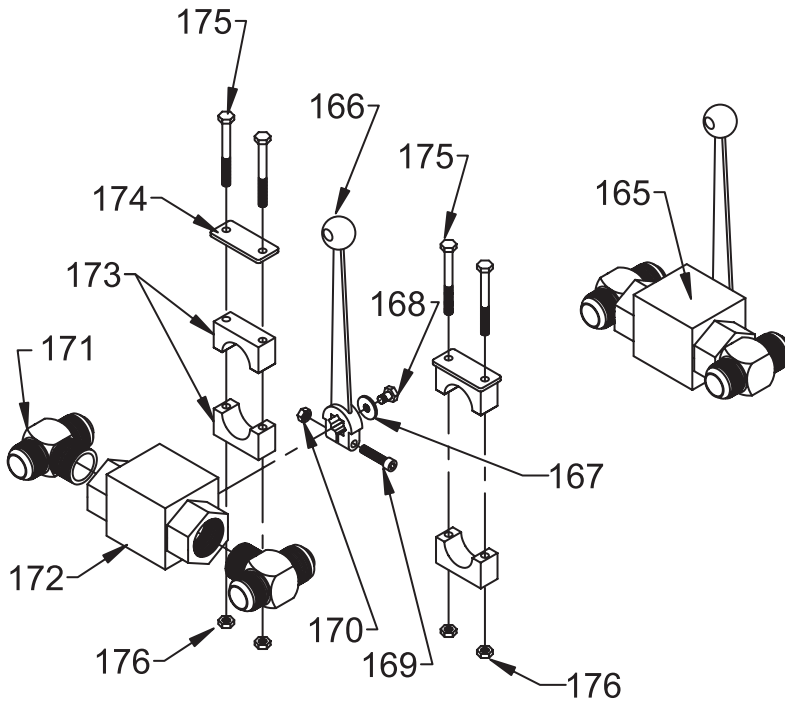

ID #	QUANTITY	DESCRIPTION	PART NUMBER
Ball Valve Assembly			
165	1	Ball Valve 1" W/ Tees & Handle	84802600
-	-	Includes items 166-172	-
166	1	Handle Ball Valve	84802900
167	1	Washer Flat 6mm	w/ball valve
168	1	Bolt Hex GR8 6mmx1mmx10mm	w/ball valve
169	1	Bolt Socket Head GR8 6mmx1mmx30mm	w/handle
170	1	Nut Hex 6mmx1mm	w/handle
171	2	2601-16-16-16 Tee	84677880
172	1	Ball Valve Assembly 1"	84802800
-	2	Clamp Hydraulic Tube 1" Kit	04631101
-	-	Includes items 173-176	-
173 ⁽¹⁾	1	Clamp Hydraulic Tube 1" Set	84750300
174	1	Plate Clamp Tube Top COP-3	84751200
175	2	Bolt Hex GR5 1/4"x2 1/4"	86419500
176	2	Nut Hex Nylock 1/4"	86626000

ELECTRIC ON/OFF BALL VALVE ASSEMBLY

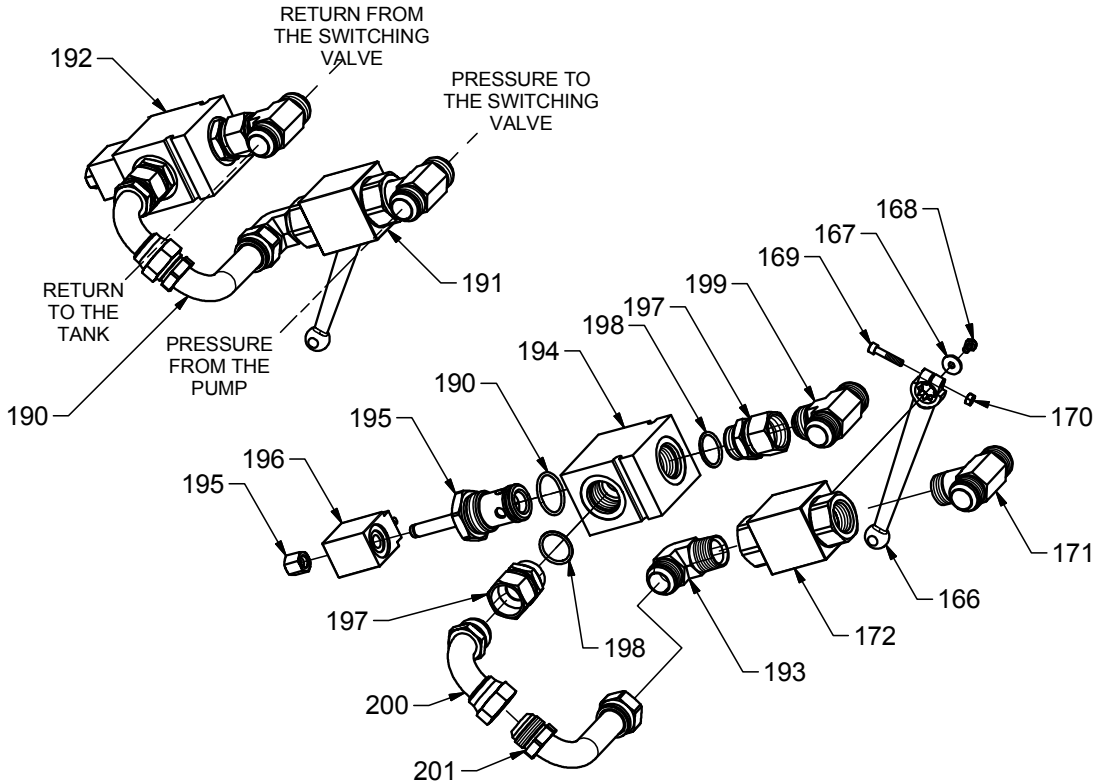
**INSTALLATION**

REMOVE THE EXISTING BALL VALVE. THE BALL VALVE IS MOUNTED ON THE FRONT OF THE DRIVE FRAME ON THE DRIVERS SIDE. THE BALL VALVE IS MOUNTED BETWEEN THE PRESSURE AND RETURN LINES. INSTALL THE ELECTRICAL ON/OFF CONTROL ASSEMBLY. CONNECT THE PRESSURE AND RETURN LINES AS SHOWN. SUPPLY ELECTRICAL POWER TO THE SOLINOID. INSTALL A SWITCH IN THE ELECTRICAL SUPPLY COIL. RUN THE WIRING IN WATER-TIGHT FLEX CONDUIT.

OPERATION

SHIFT THE BALL VALVE HANDLE TO THE OPEN POSITION. SET THE ELECTRICAL SWITCH TO THE OFF POSITION. ENGAGE THE PTO TO START THE HYDRAULIC PUMP. SWITCH THE ELECTRICAL SWITCH TO THE ON POSITION TO START THE WALKING FLOOR. THE SOLENOID COIL MUST BE ENERGIZED FOR THE WALKING FLOOR TO RUN. TO START OR STOP THE FLOOR AT THE DRIVE USING THE BALL VALVE.
 - SET ELECTICAL SWITCH TO THE OFF POSITION.
 - CLOSE THE BALL VALVE TO START THE WALKING FLOOR.
 - OPEN THE BALL VALVE TO STOP THE WALKING FLOOR.

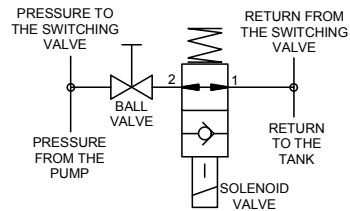
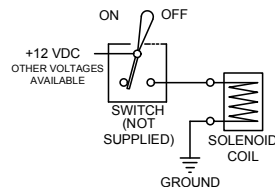
**HYDRAULIC SCHEMATIC****WIRING DIAGRAM**

#ID	QUANTITY	DESCRIPTION	PART NUMBER
ELECTRIC ON/OFF BALL VALVE PARTS LIST			
166	1	Handle Ball Valve	84802900
167	1	Washer Flat 6mm	w/ball valve
168	1	Bolt Hex GR8 6mm x 1mm x 10mm	w/ball valve
169	1	Blot Socket Head GR8 6mmx1mmx30mm	w/handle
170	1	Nut Hex 6mm x 1mm	w/handle
171	1	2601-16-16-16 Tee	84677880
172	1	Ball Valve Assembly 1"	84802800
190	1	Electric On/Off Ball Valve Assembly	3426601
		Includes items 191 & 192	
191	1	Manual On/Off Ball Valve Assembly	84802601
		Includes items 166 - 172 & 193	
192	1	Electric Solenoid Valve Assembly	85108200
		Includes items 194 - 196	
193	1	2501-16-16 Male Elbow	84677400
194	1	Body Valve 20822 566409 2-Way	85101600
195	1	Valve Cartridge SV3-20-0-0-00	85108120
196	1	Coil, 12 VDC w/Lead Wire MC 30545	85600300
197	1	6402-16-16 Swivel St. Thread Connector	84686200
198	2	916 Buna-90 O-Ring	84387800
199	1	2603-16-16-16 Union Tee	84678100
200	1	63UA-16-16 Bent Stem 90 Deg.	84683200
201	1	63UC-16-16 Long Bent Stem 90 Deg.	84683700

Restrictor Valve Assembly

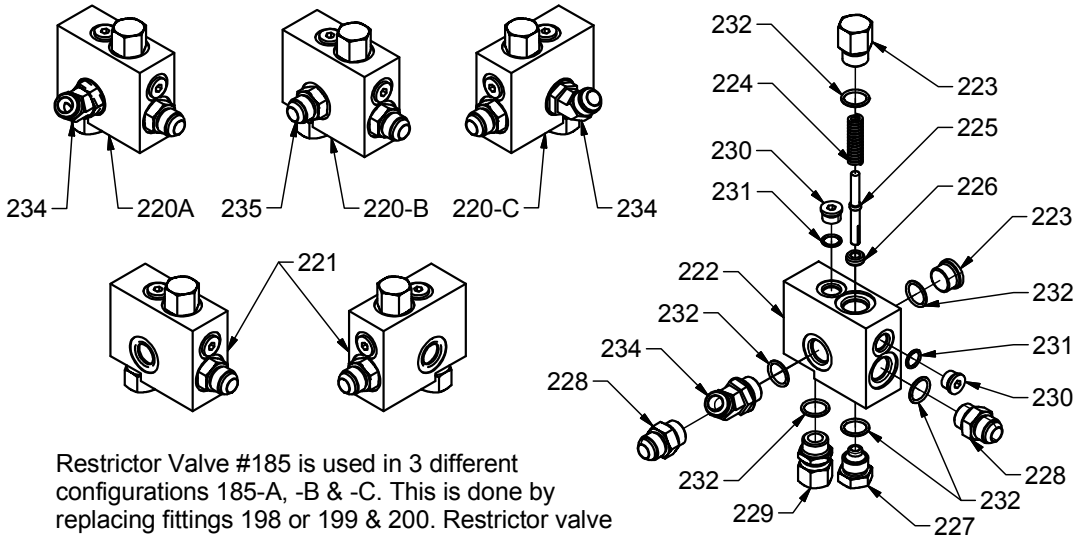

Restrictor Valve #185 is used in 3 different configurations 185-A, -B & -C. This is done by replacing fittings 198 or 199 & 200. Restrictor valve 185-A is used as front restrictor, restrictor valve 185-B is used as front restrictor on right hand DX-11 and restrictor valve 185-C is used as rear restrictor.

#ID	QUANTITY	DESCRIPTION	PART NUMBER
Restrictor Valve Parts List			
220	1	Restrictor Valve Assembly with Fittings	6549901
-	-	Includes items 256 - 269	-
221	1	Restrictor Valve Assembly without Fittings	6549902
-	-	Includes items 257 - 266	-
222	1	Restrictor Valve Body	6549601
223	1	Restrictor Rod End Cap Spring End	3349001
224	1	Spring Danly Yellow	84455400
225	1	Restrictor Rod	3348901
226	1	Restrictor Valve	1951901
227	1	Restrictor Rod End Cap Small End	3349101
228	1	6400-12-12 Straight Connector	84685000
229	1	6402-12-12 Swivel Straight Thread	84686100
230	2	6408-H-8 Hollow Hex Plug	84687500
231	2	908 O-Ring	84387000
232	6	912 O-Ring	84387400
233	1	6408-H-12 Hollow Hex Plug	84687700
234	1	6802-12-12 45° Straight Thread Elbow	84691950
235	1	6400-12-12 Straight Connector	84685000

Electric Load/Unload Control Valve

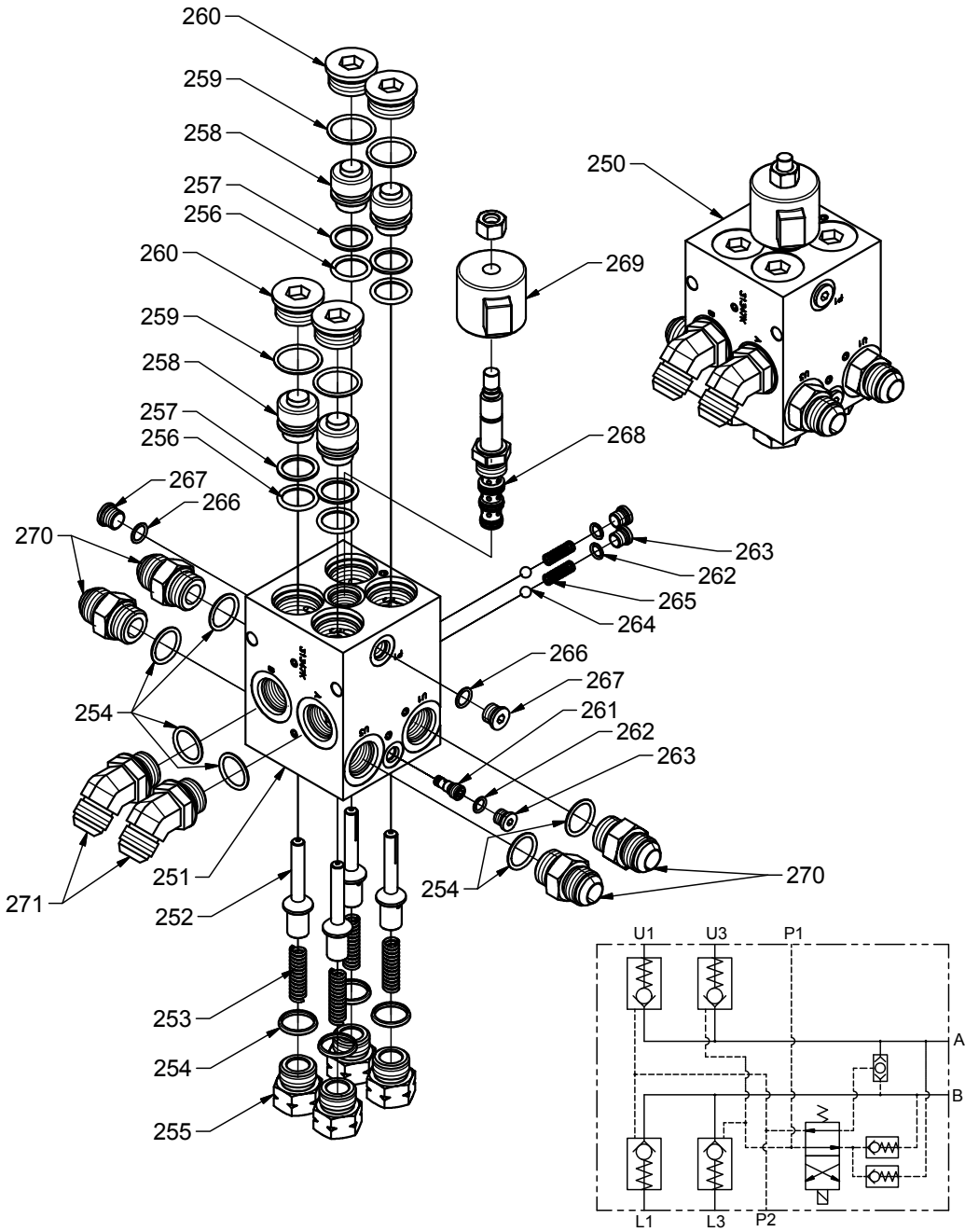

#ID	QUANTITY	DESCRIPTION	PART NUMBER
ELECTRIC LOAD/UNLOAD CONTROL VALVE PARTS LIST			
250	1	Electric Load/Unload Control Valve Assembly	3244601
		Includes items 251-269	
251	1	Electric Control Valve Body	3134701
252	4	Pilot Operated Check Valve	3138401
253	4	Ext Check Valve Spring Large	84453400
254	10	912 O-Ring	84387400
255	4	-12 Pilot Operated Spring End Cap	3860201
256	4	8-213 O-Ring	84391200
257	4	213 O-Ring	84381200
258	4	Plunger Pilot Operated Check Valve	3123601
259	4	916 O-Ring	84387800
260	4	6409-16 MSAE O-Ring Socket Plug	84687900
261	1	Shuttle Valve LS04-B-30-0-N	85104800
262	3	904 O-Ring	84386600
263	3	6409-04 MSAE O-Ring Socket Plug	84687400
264	2	5/16" Chrome Steel Ball	84800500
265	2	I-9 Spring	84450800
266	2	906 O-Ring	84386800
267	2	6409-06 MSAE O-Ring Socket Plug	84687400
268	1	SV-10-40M-12DG Solenoid Valve	85108600
269	1	Coil 115 Dac Din 6366115	85600650
270	4	6400-12-12 MSAE-MJIC Straight Connector	84685000
271	2	6802-12-12 MSAE-MJIC 45 Deg Elbow	84691975

SAE On/Off Ball Valve & Control Valve Handle Assemblies for DX11 & DX15

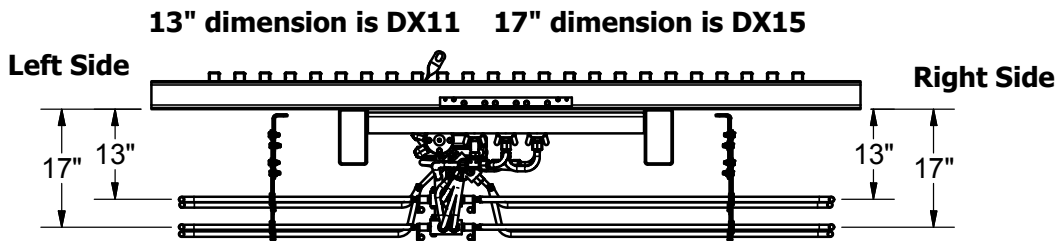
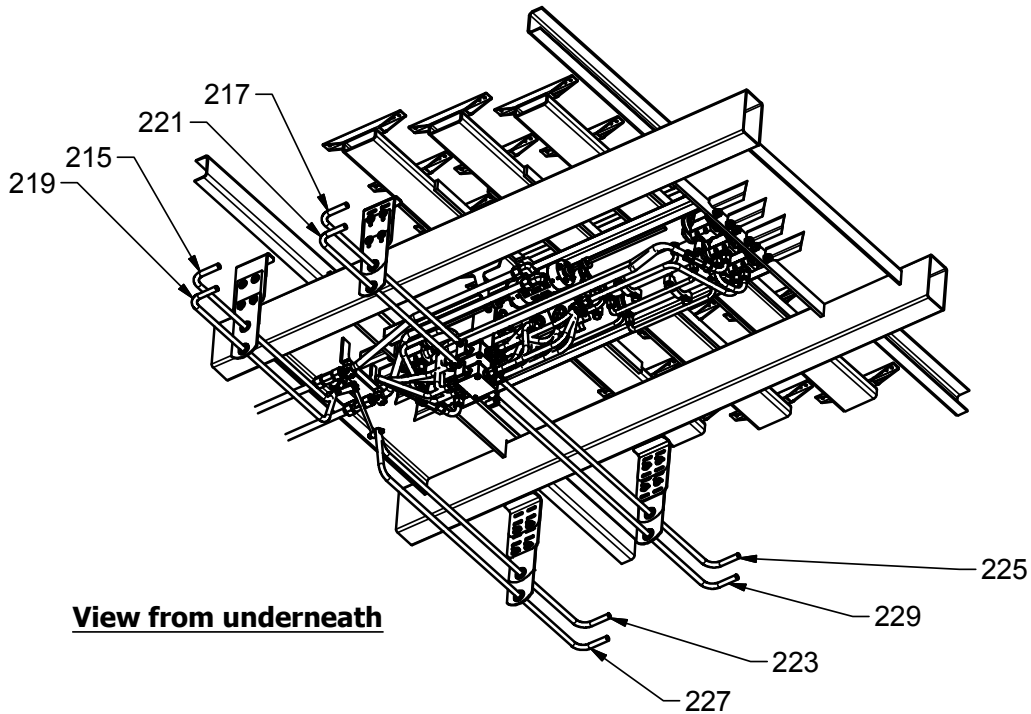

Dimensions are approximate, different drives
can vary by 1-1/4" depending on Cross-Member Height

View from rear

SAE On/Off Ball Valve & Control Valve Handle Assemblies for DX11 & DX15

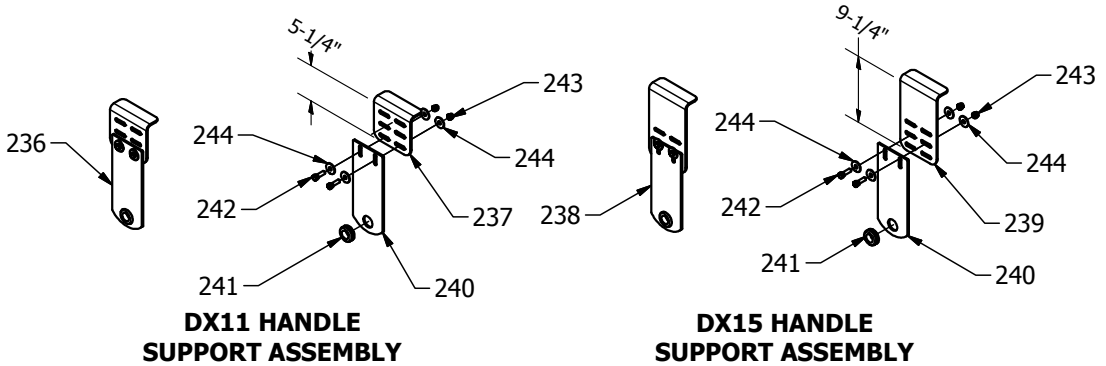
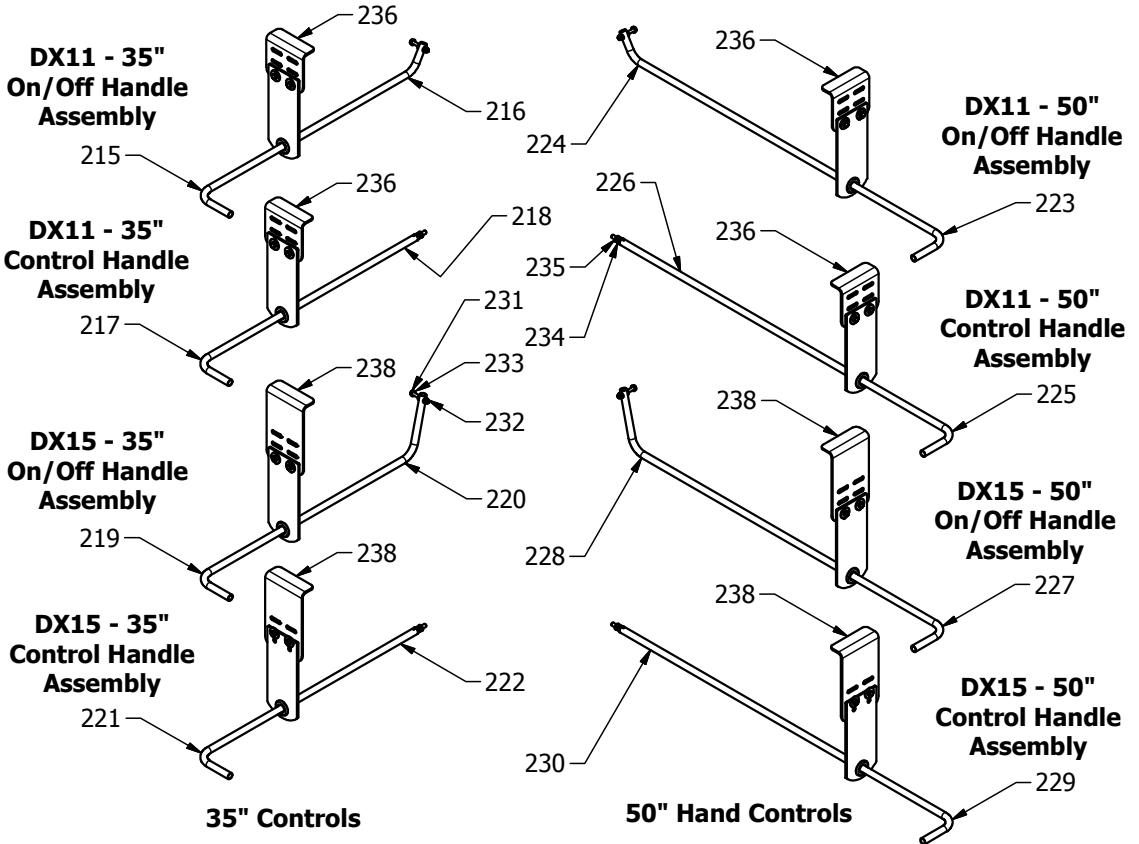

#ID	QUANTITY	DESCRIPTION	PART NUMBER
On/Off Ball Valve & Control Valve Handle Assemblies DX11 & DX15			
215	1	DX11 - 35" On/Off Ball Valve Handle Assembly	6625501
-	-	Included items 216, 231-233 & 236	-
216	1	DX11 - 35" On/Off Ball Valve Handle	6625101
217	1	DX11 - 35" Control Valve Handle Assembly	6627301
-	-	Included items 218, 234, 235 & 236	-
218	1	DX - 35" Control Valve Handle	6714801
219	1	DX15 - 35" On/Off Ball Valve Handle Assembly	6698601
-	-	Included items 220, 231-233 & 238	-
220	1	DX15 - 35" On/Off Valve Handle	6698801
221	1	DX15 - 35" Control Valve Handle Assembly	6698701
-	-	Included items 222, 234, 235 & 238	-
222	1	DX - 35" Control Valve Handle	6714801
223	1	DX11 - 50" On/Off Ball Valve Handle Assembly	6712901
-	-	Included items 224, 231-233 & 236	-
224	1	DX11 - 50" On/Off Valve Handle	6713001
225	1	DX11 - 50" Control Valve Handle Assembly	6712501
-	-	Included items 226, 234, 235 & 236	-
226	1	DX - 50" Control Valve Handle	6747601
227	1	DX15 - 50" On/Off Ball Valve Handle Assembly	6713101
-	-	Included items 228, 231-233 & 238	-
228	1	DX15 - 50" On/Off Valve Handle	6713201
229	1	DX15 - 50" Control Valve Handle Assembly	6712701
-	-	Included items 230, 234, 235 & 238	-
230	1	DX - 50" Control Valve Handle	6747601
231	1	Bolt Hex GR5 5/16" x 1-3/4"	86428500
232	1	Nut Hex Nylock 5/16"	86627500
233	3	Washer Flat 5/16"	86552500
234	1	Nut Hex 3/8"	86628500
235	1	Washer Lock 3/8"	86555000
236	1	DX11 Handle Support Assembly	6627101
-	-	Included items 237, 240-244	-
237	1	DX11 Angle Mount Plate	6625401
238	1	DX15 Handle Support Assembly	6747801
-	-	Included items 239, 240-244	-
239	1	DX15 Angle Mount Plate	6698501
240	1	On/Off & Control Valve Handle Mount Plate	3690401
241	1	Groumet Handle Support	83218400
242	2	Bolt Hex GR5 3/8" x 1-1/4"	86428500
243	2	Nut Hex Nylock 3/8"	86628000
244	4	Washer Flat 3/8"	86554000

Front Shield Assembly

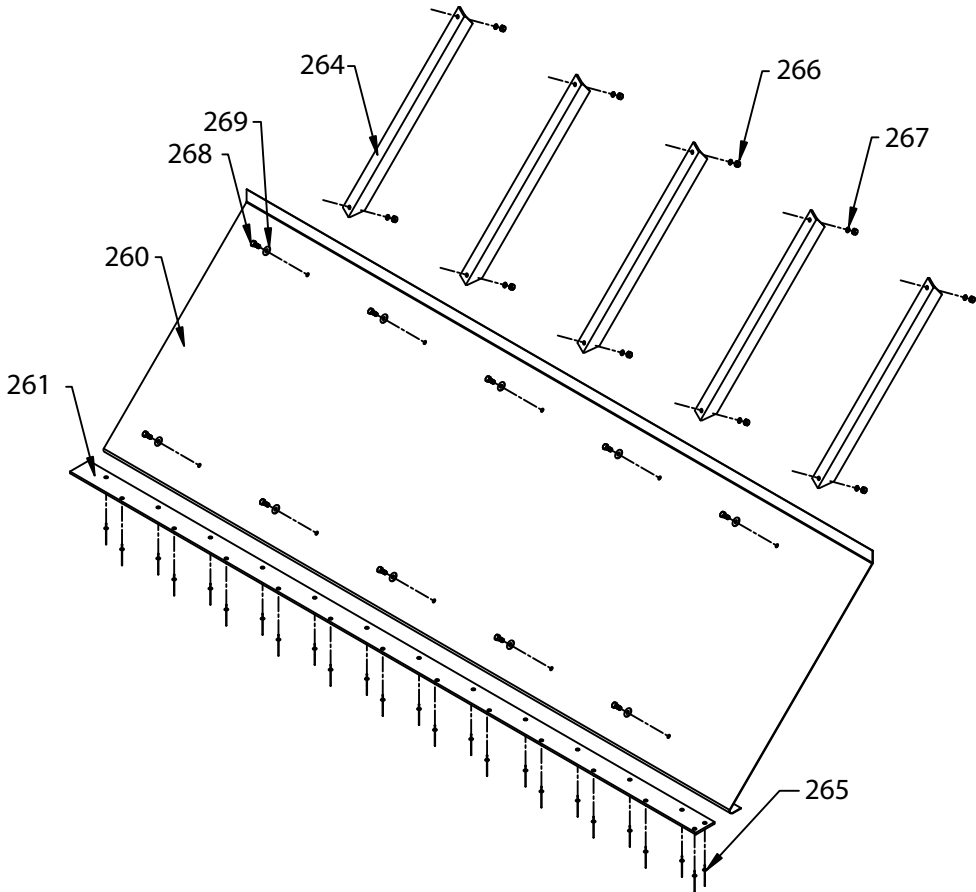

ID #	QUANTITY	DESCRIPTION
FRONT SHIELD ASSEMBLY		
-1	1	Front Shield 96" Wide Assembly
-	-	Includes items 182-189
260 ⁽¹⁾	1	Front Shield 96" Wide 14 Gauge
261 ⁽¹⁾	1	Bearing Strip Front Shield 1/4"x2 7/8"
264	5	Stiffener Angle Front Shield 1 1/2"x 1 1/2"x3/16"
265	25	Rivet 3/16"x1/2"
266	10	Nut Hex 10mm
267	10	Washer Lock 10mm
268	10	Bolt Hex 8.8 10mm x 20mm
269	10	Washer Large OD 3/8"

(1) Part numbers and descriptions vary based on trailer width and application.

(2) Quantity varies based on trailer width and application.

Floor Components

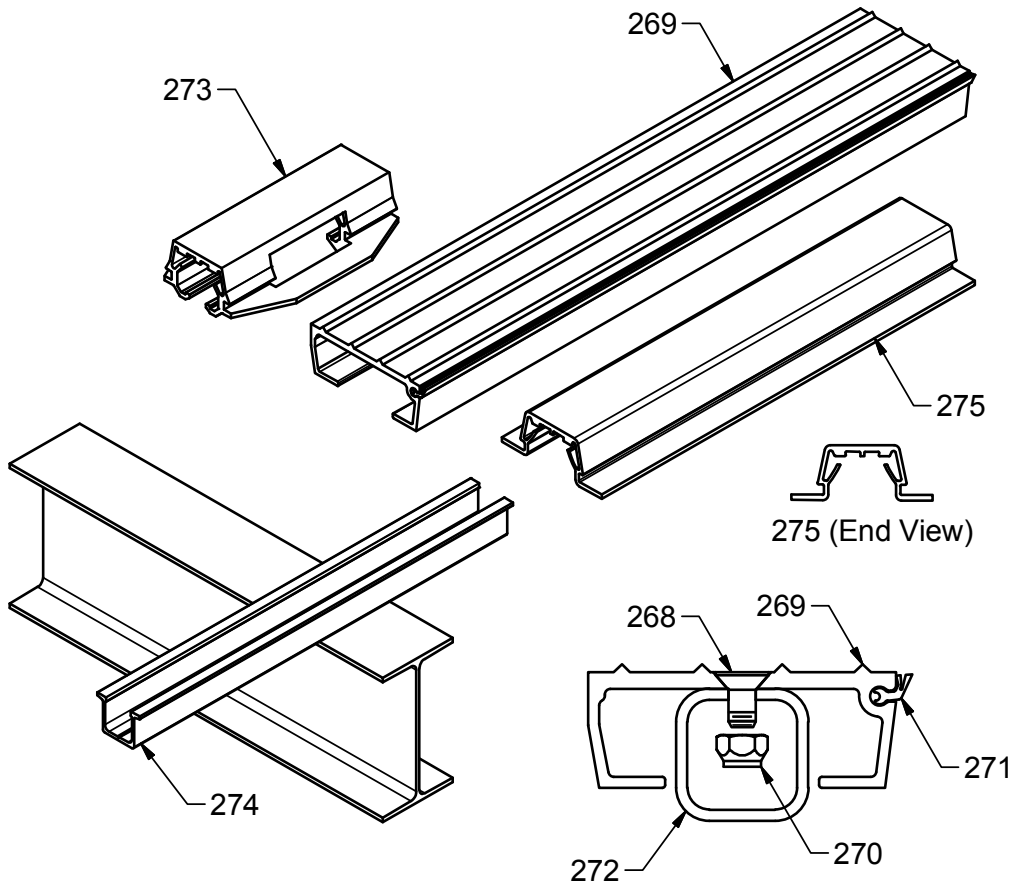

ID#	QUANTITY	DESCRIPTION	PART NUMBER
FLOOR COMPONENTS			
-	-	Includes items 268, 269, 271-275, 277, 278	-
268 ⁽¹⁾	-	Floor Bolt Socket Head Dia. & Length are Variable	-
269 ⁽¹⁾	-	Floor Slat #2188	822188SPCL
270 ⁽¹⁾	-	Nut Hex Nylock	-
271 ⁽¹⁾	-	Seal Floor #1212	83121253
272 ⁽¹⁾	-	Drive Shoe	-
273 ⁽¹⁾	-	Bearing 3.5" Floor Slat #300308	300308
274 ⁽¹⁾⁽²⁾	-	Aluminum Channel #2469	822469SPCL
275 ⁽¹⁾	-	Splash Guard Hold-Down Bearing #2468	83246801

(1) Part numbers and descriptions vary based on trailer width and application.

(2) Channel is also available in 44' lengths (8224694400) and 48' lengths (8224694800)

* The last four digits in a ten part number refers to length in feet and inches (Example 8222954305 is 43'05" long).

Floor Components

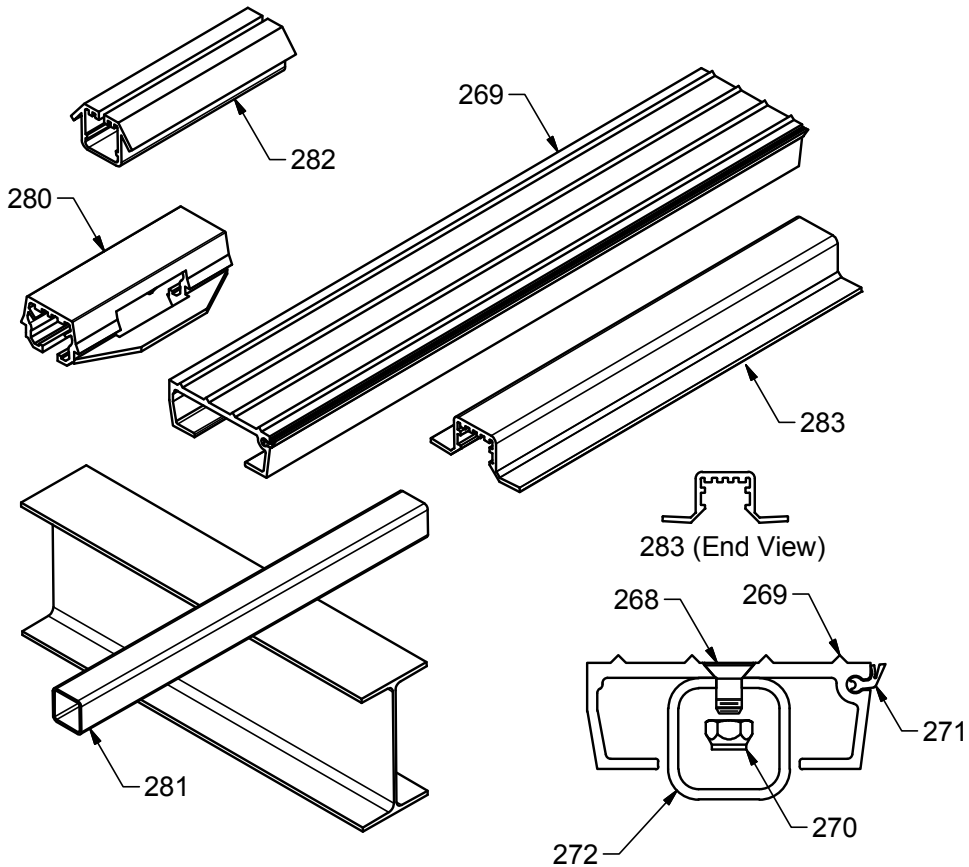

FLOOR COMPONENTS

-	-	Includes items 268-276
268 ⁽¹⁾	-	Floor Bolt Socket Head Dia. & Length are Variable
269 ⁽¹⁾	-	Floor Slat #2188
270 ⁽¹⁾	-	Nut Hex Nylock
271 ⁽¹⁾	-	Seal Floor #1212
272 ⁽¹⁾	-	Drive Shoe
280 ⁽¹⁾	-	Bearing 3.5" #3003
281 ⁽¹⁾	-	Subdeck 1" x 1" x .063" x 20' Steel Tube
282 ⁽¹⁾	-	Bearing Hold-Down 3.5" Floor Slat #3004
283 ⁽¹⁾	-	Splash Guard Bearing (Not Hold Down) #2228

(1) Part numbers and descriptions vary based on trailer width and application.

* The last four digits in a ten part number refers to length in feet and inches (Example 8222954305 is 43'05" long).

**Maintenance For Your New
KEITH® RUNNING FLOOR II® DX and Hydraulic Wet Kit**

1. For proper operation of your new RUNNING FLOOR II® DX equipped trailer and wet kit, make sure the pressure and return lines are hooked up correctly. It is important to periodically inspect hoses and connectors for damage and contamination. Clean all dirt and water from connectors before hooking up.
2. Change the hydraulic return filter element after the first six (6) hours of operation and then every six (6) months. This may vary with the operating environment.
3. During the first two (2) weeks of operation, it will be necessary to check and tighten all floor bolts. Floor bolts should be checked regularly for proper torque, in accordance with a preventive maintenance program, as loose floor bolts will cause serious damage to floor slats.
4. After the first week of operation, you must check and tighten the lower cross-drive clamp bolts that fasten the cross-drives to the cylinder. Also check the end cylinder rod plate bolts that fasten the cylinders to the drive frame.
5. During the first several weeks of operation, examine the check valve and tube clamps regularly to ensure that they are securely fastened.
6. It is recommended to pressure wash the top of the floor slats and seal every six months.

Bolt Description	Recommended Bolt Torque Values	Torque
Bolt Floor 5/16" FHCS	82° flat head floor bolt	22 FT-LBS
Bolt Floor 3/8" FHCS	82° flat head floor bolt	42 FT-LBS
Bolt Hex 5/8" HCS	Lower cross-drive clamp bolt (Over torque may distort the barrel enough to bind the piston.)	135 FT-LBS
Bolt Hex 5/8" HCS	Rod end plates	135 FT-LBS
Bolt Hex 5/16" HCS	Check valve and tube clamp bolts	20 FT-LBS

Problems and Trouble-Shooting

KEITH Mfg. Co. 24-hour Fax Service (541) 475-2169
 KEITH Mfg. Co. Customer Service and Support (800) 547-6161 or (541) 475-3802
 Monday - Friday, 7 am to 4 pm Pacific Standard Time
 Email: techdept@keithwalkingfloor.com

Before you call, please review the following:

1. See start-up check list on page 11.
 Re-checking items on this list can solve most problems.
2. We will be better able to help solve any problems if you have the information indicated below before you call.
 - a. Drive Model Number
 - b. Drive Serial Number
 - c. Number of floor slats
 - d. Trailer make
 - e. Cylinder bore size

**PLEASE FILL OUT AND RETURN IMMEDIATELY TO
KEITH Mfg. Co.**

The warranty registration card must be completed and on file at KEITH Mfg. Co. in order for the warranty period to begin on the purchase date. If no purchase date is registered, the beginning of the warranty will be the date of the manufacture if no other date can be determined.

Please make sure the serial number listed on the card coincides with the serial number plate on the drive unit.

**Please print or type
KEITH® RUNNING FLOOR II® DX Warranty Registration Card**

Purchaser		
Address		Phone
City		State/Prov.
Country		Postal Code
Original Purchase Date of System		
KEITH Model No.		
KEITH Serial No. (See page 9, 10 for location guide)		
Installed in:	New Trailer	Used Trailer
Dealer Name & Location		
Type of Material Unloaded		

I have fully read the KEITH Mfg. Co. warranty information and I/we fully understand and agree to the terms of the warranty.

Signature _____ Date _____

Note: To validate the warranty, this registration card must be filled out completely and returned to KEITH Mfg. Co. within ten (10) days of purchase and/or installation.

Please fax, mail or email this warranty registration information to KEITH Mfg. Co. at:

**Warranty Registration
KEITH Mfg. Co.
P.O. Box 1
Madras, OR 97741-0001
Fax: (541) 475-2169
Email: techdept@keithwalkingfloor.com**

CUT HERE

Warranty Return Policy

1. Contact KEITH Mfg. Co. at 1-800-547-6161 or techdept@keithwalkingfloor.com for a "Returned Goods Authorization" (RGA) number before returning any item for repair or replacement. The following information is needed to ensure parts are returned as quickly as possible.

- | | |
|-----------------|------------------------------|
| a. Company name | e. Part number |
| b. Contact name | f. Quantity |
| c. Address | g. Reason for return |
| d. Phone number | h. Customer's account number |

2. Prior approval and a RGA number is needed when returning any unused product for credit. Make sure the RGA number is on the outside of the shipping carton and all paperwork is included. Return all material on a Freight Prepaid Basis.

!!CAUTION!!

To prevent Possible Injury or Death

DO NOT:

1. Operate the floor with the doors closed.
2. Stand behind the trailer or in the discharge area when floor is operating.
3. Make adjustments to the unloading mechanism with floor operating.
4. Operate the unloader when protective covers and screens are not in place.
5. Go underneath the trailer when floor is operating.
6. Leave the trailer unattended while the unloader is in operation.

ALWAYS:

1. Disengage the trailer from the hydraulic power unit (P.T.O.) before service and maintenance.
2. Shut off the power supply before going underneath the trailer.
3. Stay away from any oil leaks when hydraulic pressure is high.
4. Shut off the hydraulic power take off unit (P.T.O.) before moving the trailer.
5. Make certain no one is in the trailer during loading.

!!Keep your hands, body parts and loose clothing away from the floor slats and drive mechanism when the unloading system is in operation!!



KEITH